

Catalogue

PREMIUM

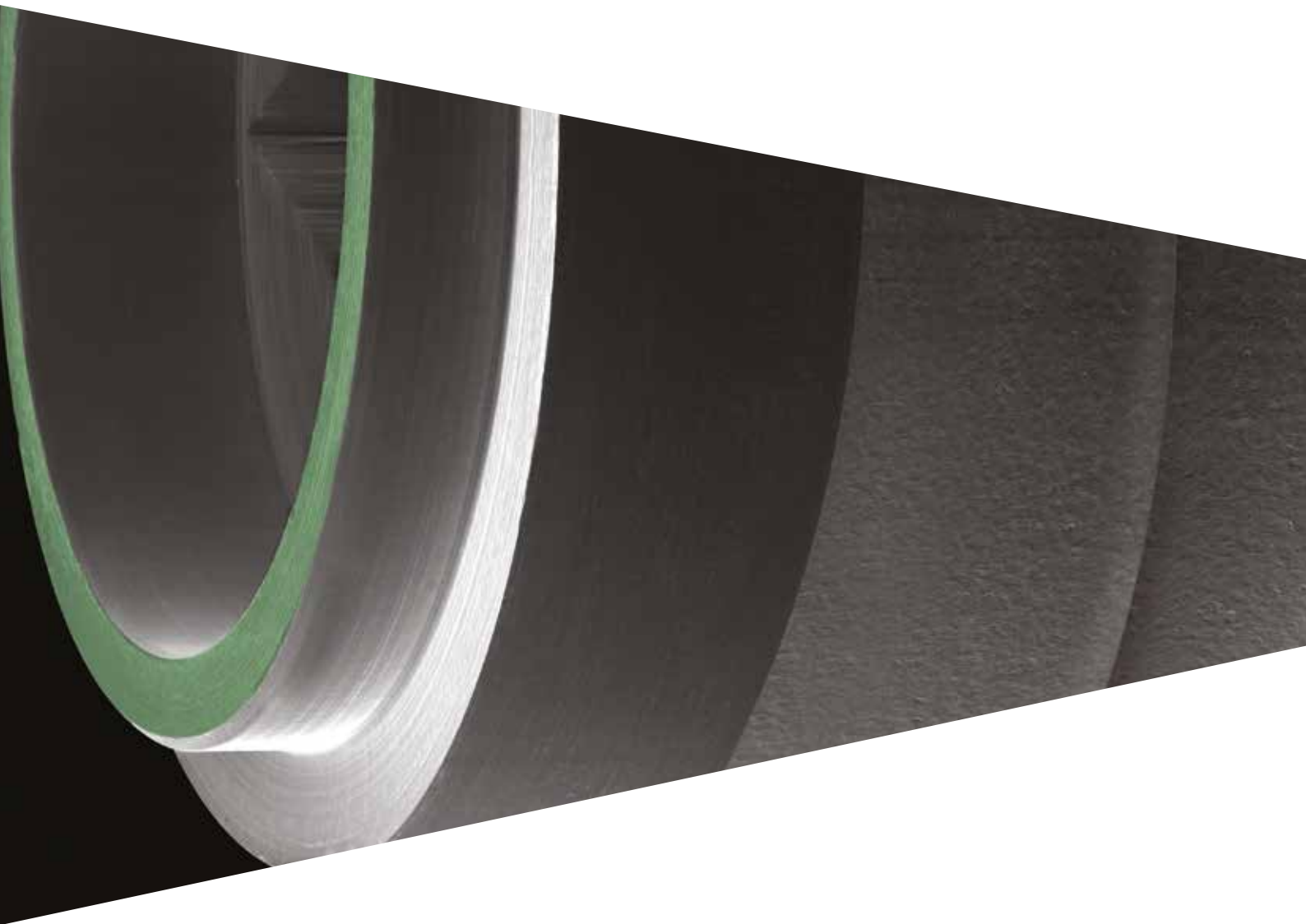

Some products may not be regulatory cleared/released for sale in all markets.
Please contact the local Sweden & Martina or distributor sales office for current products availability.

Premium

Table of contents

	Complete range	4
	ZirTi surface	4
	Availability	5
	The Premium range	6
	Collex connection	8
	Switching Platform	10
	Summary table	12
	Mountless surgical procedure	14
	Surgical instruments	15
	The surgical and prosthetic kits	15
	Surgical kit	16
	OneBox	18
	Screw kit	19
	Initial, intermediate and countersink drills	20
	Final drills and stops	22
	Drills for distal sectors	24
	Osteotomes	26
	Bone taps	27
	Additional instruments	28
	Bone profilers	35
	Shorty drilling kit	36
	Premium prosthetic components	40
	Healing abutments	40
	Impression and model phase	42
	SIMPLE temporary posts	46
	Pre-made posts	48
	Standard millable posts	52
	Millable posts	54
	B.O.P.T. prosthesis	56
	Castable posts with base in alloy, titanium and cobalt chrome	58
	Entirely castable posts	60
	Prosthesis on intermediate abutments	62
	P.A.D. (Disparallel Screwed Prosthesis)	64
	Straight P.A.D.	66
	Angled P.A.D.	67
	P.A.D. components for the relined and the cemented technique	71
	P.A.D. prosthesis for "D.P.F." Technique (Direct Prosthetic Framework)	72
	Prosthesis on PLAIN abutments	74
	T-Connect	76
	Try-in kit	78
	Overdenture	80
	Locator Abutment	80
	Overdentures anchored with ball attachments	82
	SFI-Bar	84
	Accessories for overdentures on Locator abutments	88
	Accessories for overdentures on ball attachments	90
	Overdentures on bars	91
	Material components	92
	Bibliography on Sweden & Martina implants	96

ZirTi Surface

Both the versions of Premium implants (Straight and SP) are available with a machined neck and a body with ZirTi treatment.

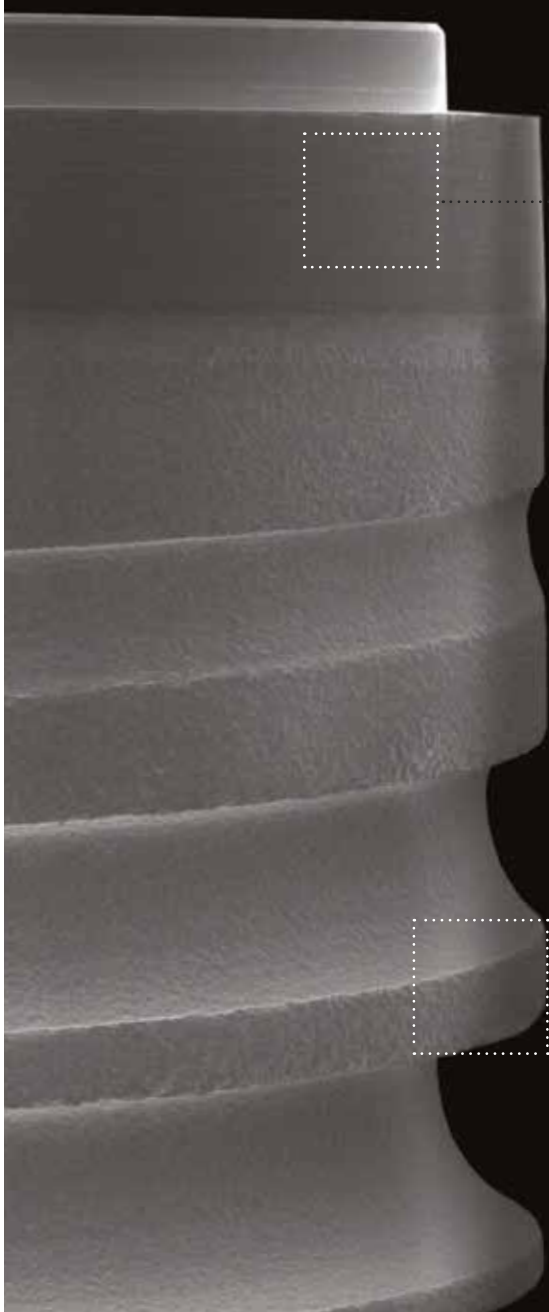

Machined surface



The **machined neck** allows the perfect control of the connection diameter and prevents the accumulation of plaque in the area where it joins the post.

ZirTi surface

(Zirconium Sand-Blasted Acid Etched Titanium)

The implant body is treated with appropriate subtraction techniques that give the surface the characteristic ZirTi morphology, able to significantly increase the bone-implant contact surface and ensure excellent primary stability. The ZirTi surface has shown to have a sub-layer that promotes cell regrowth, such as to adequately boost its differentiation and proliferation.

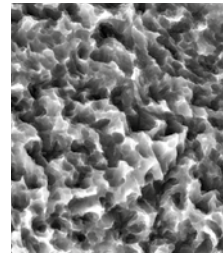



Image from the Sweden & Martina archives

Availability

		PREMIUM STRAIGHT	PREMIUMSP
			
diameter	length	code	code
3.30	8.50	A-ZT-330-085	-
	10.00	A-ZT-330-100	-
	11.50	A-ZT-330-115	-
	13.00	A-ZT-330-130	-
	15.00	A-ZT-330-150	-
3.80	8.50	A-ZT-380-085	A-ZT-380SP-085
	10.00	A-ZT-380-100	A-ZT-380SP-100
	11.50	A-ZT-380-115	A-ZT-380SP-115
	13.00	A-ZT-380-130	A-ZT-380SP-130
	15.00	A-ZT-380-150	A-ZT-380SP-150
	18.00	A-ZT-380-180	-
4.25	7.00	A-ZT-425-070	A-ZT-425SP-070
	8.50	A-ZT-425-085	A-ZT-425SP-085
	10.00	A-ZT-425-100	A-ZT-425SP-100
	11.50	A-ZT-425-115	A-ZT-425SP-115
	13.00	A-ZT-425-130	A-ZT-425SP-130
	15.00	A-ZT-425-150	A-ZT-425SP-150
	18.00	A-ZT-425-180	-
5.00	7.00	A-ZT-500-070	A-ZT-500SP-070
	8.50	A-ZT-500-085	A-ZT-500SP-085
	10.00	A-ZT-500-100	A-ZT-500SP-100
	11.50	A-ZT-500-115	A-ZT-500SP-115
	13.00	A-ZT-500-130	A-ZT-500SP-130
	15.00	A-ZT-500-150	A-ZT-500SP-150

Key to the implant codes

The implant codes are so-called “mnemonic” codes, i.e. they allow easy identification of the piece.











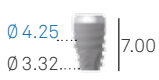
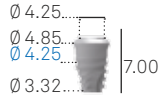

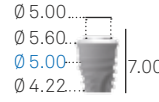
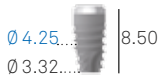



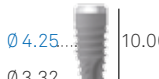



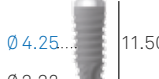

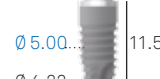

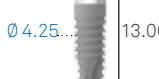
Below is a table showing how the mnemonic codes work using code A-ZT-425SP-115 as an example:

Type of implant	Surface	Diameter	Emergence	Length
A-	ZT-	425	SP-	115
A: Premium Implant	ZT: ZirTi Surface	330: 3.30 mm 380: 3.80 mm 425: 4.25 mm 500: 5.00 mm	SP: Switching Platform if no specifications are available, it refers to a standard STRAIGHT connection	070: 7.00 mm 085: 8.50 mm 100: 10.00 mm 115: 11.50 mm 130: 13.00 mm 150: 15.00 mm 180: 18.00 mm refers to the length of the implant
		it's the size of the platform of the implant connection		

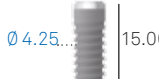
The Premium range

	3.30 mm		3.80 mm	
	Straight	SP	Straight	SP
7.00	-	-	-	-
8.50	A-ZT-330-085 	-	A-ZT-380-085 	A-ZT-380SP-085 
10.00	A-ZT-330-100 	-	A-ZT-380-100 	A-ZT-380SP-100 
11.50	A-ZT-330-115 	-	A-ZT-380-115 	A-ZT-380SP-115 
13.00	A-ZT-330-130 	-	A-ZT-380-130 	A-ZT-380SP-130 
15.00	A-ZT-330-150 	-	A-ZT-380-150 	A-ZT-380SP-150 
18.00	-	-	A-ZT-380-180 	-
surgical cover screws	A-VT-330 	Use A-VT-330	A-VT-380 	Use A-VT-380

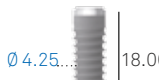
- Ø 3.30 mm implants: The use of the Premium Ø 3.30 mm implants is only for replacing the central and lateral incisors and upper and lower canine teeth. They can also be used in the pre-molar and molar zone, but only to support the prosthetic structures which are also supported by implants with a bigger diameter.
- Shorty implants are characterised by a reduced vertical dimension, it is recommended to use them with implants with traditional dimensions with joined prostheses.

	4.25 mm		5.00 mm	
	Straight	SP	Straight	SP
7.00	A-ZT-425-070 	A-ZT-425SP-070 	A-ZT-500-070 	A-ZT-500SP-070 
8.50	A-ZT-425-085 	A-ZT-425SP-085 	A-ZT-500-085 	A-ZT-500SP-085 
10.00	A-ZT-425-100 	A-ZT-425SP-100 	A-ZT-500-100 	A-ZT-500SP-100 
11.50	A-ZT-425-115 	A-ZT-425SP-115 	A-ZT-500-115 	A-ZT-500SP-115 
13.00	A-ZT-425-130 	A-ZT-425SP-130 	A-ZT-500-130 	A-ZT-500SP-130 
15.00	A-ZT-425-150 	A-ZT-425SP-150 	A-ZT-500-150 	A-ZT-500SP-150 
18.00	A-ZT-425-180 	-	-	-
surgical cover screws	A-VT-425 	Use A-VT-425	A-VT-500 	Use A-VT-500

Premium SP: The length includes the portion relating to the bevel (the counter-conical upper portion of the collar that brings the crown diameter back to the diameter of the connection platform). It is equal to the length of the holes produced by the relative drills. If you want to leave the juxta-osseous bevel, simply screw the implants up to the desired level.

All measurements are given in mm, unless indicated otherwise

Collex connection

Premium cylindrical implants, in both the version with Straight cylindrical emergence and the version with SP enlarged emergence, while offering different surgical options thanks to their different emergence, have a common connection platform for the restoring doctor which makes the dental surgeon's job easier.



Straight

SP



Bevel

The widening generated by the bevel in SP implants allows the crestal bone to be distanced from the implant connection by 0.30 mm in a horizontal direction and 0.50 mm in a vertical direction, thus offering a Switching Platform embedded in the morphology of the implant.

Collar

Implants with a diameter greater than 3.30 mm have a collar on top of the neck that gives great maximum stability to the connection and aids the correct distribution of the masticatory forces, which are unloaded along the entire implant perimeter. It also creates a stabilising connection for the post, capable of reducing mid-distal and lingual-vestibule movements.

The internal part of the collar allows safe and easy engaging of the insertion driver.

Internal hexagon for repositioning of the prosthesis

Located in a coronal position, it is characterised by excellent visibility. The 60° repositioning and the total connection depth of almost 2.00 mm ensure non-rotation and precision.

Connection Ø 3.30 mm



Collar

In Premium implants with Ø 3.30 mm, the internal collar performs the same prosthesis stabilising function performed by the external collar in all the other implant diameter dimensions.

Internal hexagon for repositioning of the prosthesis

Located in a coronal position, it is characterised by excellent visibility. The 60° repositioning and the total connection depth of almost 2.00 mm ensure non-rotation and precision. The dimensions of the hexagon are the same as in Ø 3.80 mm implants.

Connection similarities

Same hexagon, but in diameter 3.30 the collar is inside the platform.



Premium Ø 3.30 mm



Premium Ø 3.80 mm



Premium Ø 4.25 mm



Premium Ø 5.00 mm

In these implant diameters the hexagon is the same, the internal diameter of the collar on top of the hexagon is the same, but it widens externally in the three different diameters.

Switching Platform

The Switching Platform is a prosthetic rehabilitation technique that aims to distance the prosthetic connection platform from the cervical bone.

In fact, the abutment-implant junction is today indicated as one of the factors responsible for peri-implant bone reabsorption because it can trigger inflammatory reactions.

Clinical findings relating to the use of Premium Switching Platform implants confirm the reliability of the Switching Platform technique with Premium implants.



Ground Section of Premium Switching Platform implant 4 months after insertion.

Image by kind permission of Dr D. Botticelli



Diameters being equal, implants with Straight emergence and Switching Platform emergence use the same prosthetic components.

The Switching Platform technique used in this case is incorporated in the implant morphology.

Switching Platform on Straight implants Ø 3.80 mm

If the morphology of the receiving bone does not allow the use of implants with an enlarged coronal diameter and it is therefore necessary to use an implant with a straight coronal emergence, it is still possible to employ a prosthetic Switching Platform on implants with diameter 3.80 mm, using a post with a smaller diameter (3.30 mm).



With this configuration the Switching Platform that can be obtained on either side is 0.325 mm horizontally and 0.35 mm vertically.

Switching Platform on SP implants Ø 3.80 mm

If implants with SP emergence can be used and you want to maximise mismatching between the level of the bone crest and the join between implant and prosthesis, the combined use of an SP implant and a post with a smaller diameter, as in the drawing below, allows you to obtain a highly accentuated Switching Platform.

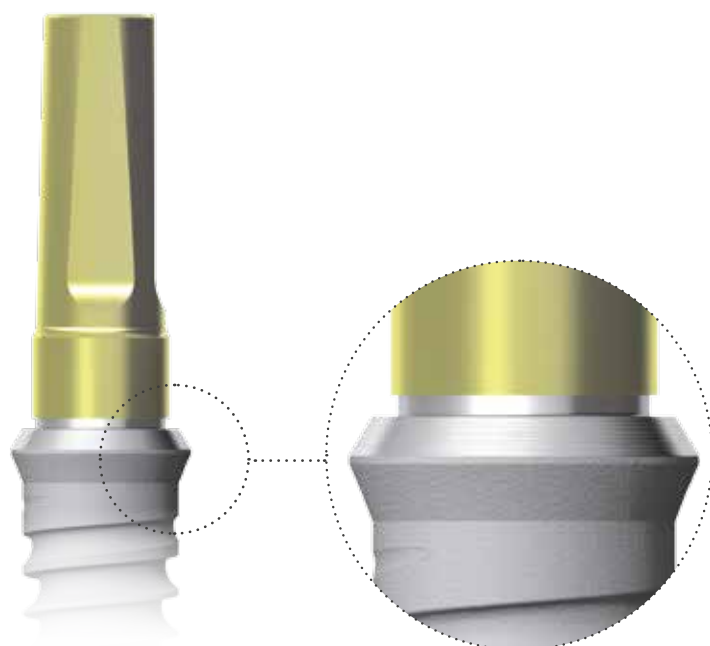































































With this configuration, with a Ø 3.80 mm SP implant and a Ø 3.30 mm post the total Switching Platform that can be obtained on either side is 1.25 mm.

Important warning

Considering the reduced diameter of Ø 3.30 mm prosthetic components, it is recommended to use them to obtain Switching Platform with 3.80 mm implants exclusively for single crown in front sectors (excluding premolars), while in distal sectors they must be used exclusively as a support for multiple prostheses.

Summary table

implant morphology	PREMIUM STRAIGHT			
implant Ø	3.30 Straight	3.80 Straight	4.25 Straight	5.00 Straight
reference colour code on surgical tray				
colour code (on pack)				
connection platform Ø collar external Ø				
main dimensions				
connection driver hexagon colour code				
Easy Insert				
	Hexagon: 2.30 mm	Hexagon: 2.30 mm	Hexagon: 2.50 mm	Hexagon: 2.50 mm
standard final drill				
	Ø 2.80 mm	Ø 3.00 mm	Ø 3.40 mm	Ø 4.25 mm
connecting screw (thread and colour)				
	M 1.8	M 1.8	M 2.0	M 2.0
transfer colour code				
analog colour code				

implant morphology	PREMIUMSP		
implant Ø	3.80 SP	4.25 SP	5.00 SP
reference colour code on surgical tray			
colour code (on pack)			
maximum emergence Ø connection platform Ø collar external Ø			
main dimensions			
connection driver hexagon colour code			
Easy Insert			
	Hexagon: 2.30 mm	Hexagon: 2.50 mm	Hexagon: 2.50 mm
standard final drill			
	Ø 3.00 mm	Ø 3.40 mm	Ø 4.25 mm
connecting screw (thread and colour)			
	M 1.8	M 2.0	M 2.0
transfer colour code			
analog colour code			

Mountless surgical procedure

The surgical procedure of insertion is extremely simple. The implant does not require a mounter for inserting into the implant site because it is engaged directly inside the connection by practical Easy Insert drivers designed to guarantee a safe grip, to prevent deformations to the corners of the connections and at the same time to allow easy removal from the implant wells.



The **colour code** on the instrument shank and on the retaining metal o-rings facilitates the identification and choice of the item needed.

The Easy Insert drivers aid **visibility of the operating field**, do not occupy much space, and allow adjusting the connection hexagon properly because their hexagonal visual index is the same as a prosthetic index.

Engagement is extremely safe and reliable with the use of a special **titanium o-ring** that engages inside the connection.

The presence of a wide hexagon at the base of the prosthetic cone allows **easy and safe engagement** of the Easy Insert drivers for easy and safe insertion of the implants into the respective sites.

The image on the left shows how a traditional instrument (in blue) edges inside the connection (in grey). This geometry inevitably determines the grip and deformation of the actual session.

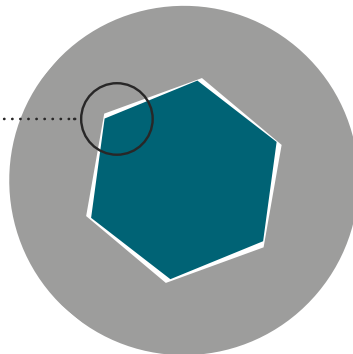

The **dodecagonal design** of the drivers prevents deformations to the implant connection, thus guaranteeing extremely high prosthetic stability and precision.

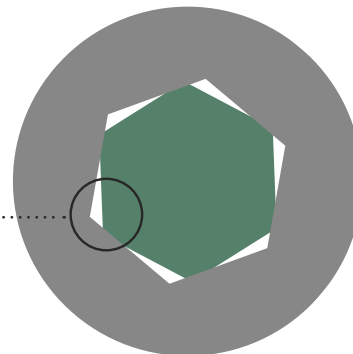

The special design of the Easy Insert drivers (in green in the section on the right) enables the driver and implant to interact on a portion of the surface in the centre of the connection hexagon.

Easy Insert drivers are available with two different hexagons, characterised by the colours blue and magenta, to be used according to the implant connection.

	Ø 3.30 mm	Ø 3.80 mm	Ø 4.25 mm	Ø 5.00 mm
Premium Straight	●	●	●	●
Premium SP	●	●	●	●

The surgical and prosthetic kits

In a single kit all the surgical instruments for the whole Premium range, in both versions Straight and SP.

Premium Surgical Kit



Drilling Kit Shorty



A complete kit with all the indispensable instruments to ensure the surgeon of the rapid availability of everything needed for the Shorty implants surgical necessities.

This kit was created to meet the needs of surgeons who carry out a large number of implant surgeries, and it includes the surgical instruments for the implant insertion phase.

Onebox Kit



Screw Kit



The Screw kit is a small set which includes the instruments necessary for the prosthetic phases.

Surgical kit

The surgical kit for the Premium implant system have been designed for maximum simplicity and ergonomics.

The instrument codes are printed on the tray to allow the assistants to easily reposition them after cleansing and cleaning.



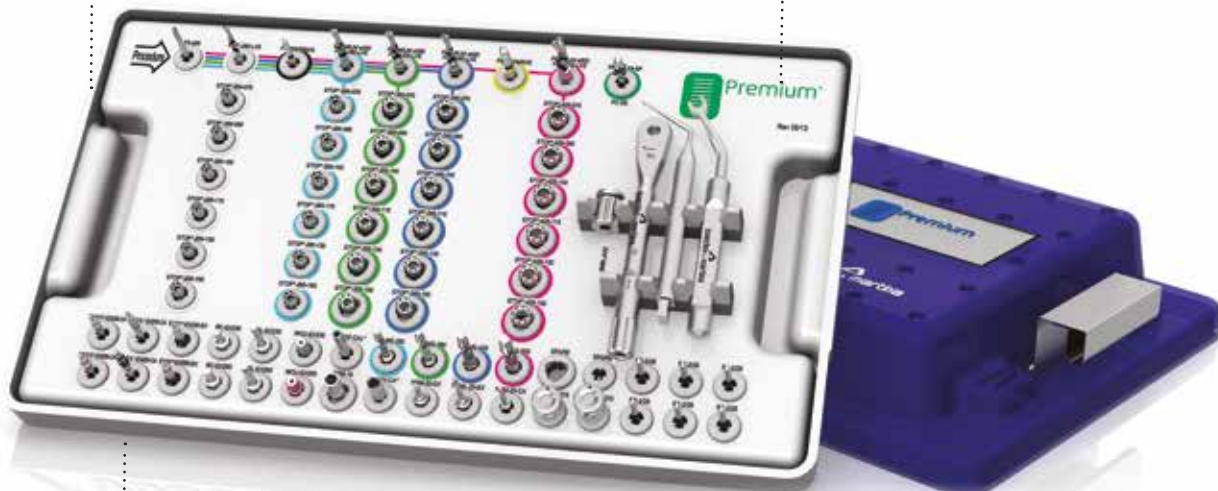

The standard surgical kit contains the stops for safely using the drills (they do not include countersinks and bone profilers). These stops are extremely practical because they allow manually inserting and removing drills in tip → shank direction. The instruments contained in the kit are all made of steel specifically for surgical use.



It contains all the surgical and prosthetic instruments needed for both the implants in the Premium family.

Important warning

To guarantee maximum duration of the surgical and prosthetic instruments, it is advisable to follow the recommended cleansing and sterilisation procedures.

description	code
<p>Surgical kit complete with the instruments necessary for Premium implants</p> <p>Radel instrument tray for Premium implants</p>	<p>ZPREMIUM-INT</p> <p>PRE-KIT</p> 
<p>Kit with 5 spare silicon supports for surgical trays, for drills or instruments with right angle shanks</p>	<p>GROMMET-3</p> 
<p>Kit with 5 spare silicon supports for surgical trays, for hand use instruments or hand knobs</p>	<p>GROMMET-4</p> 
<p>Kit with 5 spare silicon supports for surgical trays, for digital or manual handheld instruments</p>	<p>GROMMET-5</p> 

OneBox

The OneBox surgical kit was created to meet the needs of surgeons who carry out a large number of implant operations and therefore want to have a compact kit equipped essentially with all that is needed only for the surgical phase.

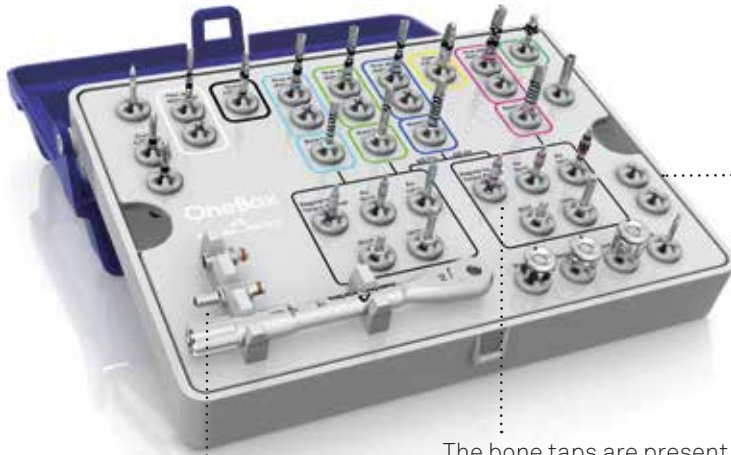

The OneBox is a compact kit that is easy to carry, containing the surgical instruments strictly necessary for inserting Premium implants.



This kit contains space for an additional series of alternative drills, which the surgeon may wish to choose and use depending on his experience.

The bone taps are present in the kit in the version with right angle attachment.

It does not contain drill stops or prosthetic drivers, but it contains all the drivers in the one-piece hand use version and the right angle version, which are much more practical during surgical procedures.

description	code
OneBox surgical kit complete with the instruments for Premium implants OneBox Radel instrument tray for Premium instruments	ZAONEBOX-INT AONEBOX-KIT 
Kit with 5 spare silicon supports for surgical trays, for drills or instruments with right angle shanks	GROMMET-CA-1 
Kit with 5 spare silicon supports for surgical trays, for instruments fitted with connection hexagon	GROMMET-CA-2 

Important warning

To guarantee maximum duration of the surgical and prosthetic instruments, it is advisable to follow the recommended cleansing and sterilisation procedures.



Screw kit

The Sweden & Martina Screw kit is a handy set containing the drivers necessary for the prosthetic phases, from the removal of the Premium transgingival healing screws to the final fastening of the over-structures, the drivers for standard abutments, straight profile P.A.D. and Locators and the drivers for ball attachments.



It includes digital and right angle drivers, a carrier for angled P.A.D. abutments and a dynamometric ratchet.

Small and easy to carry, it allows simple and immediate management of the prosthetic rehabilitation phase after surgery.

description	code
Screw kit complete with prosthetic instruments Radel instrument tray for Screw kit	ZSCREW-INT SCREW-TRAY 
Kit with 5 spare silicon supports for surgical trays, for drills or instruments with right angle shanks	GROMMET-CA-1 
Kit with 5 spare silicon supports for surgical trays, for instruments fitted with connection hexagon	GROMMET-CA-2 

Important warning

To guarantee maximum duration of the surgical and prosthetic instruments, it is advisable to follow the recommended cleansing and sterilisation procedures.

Initial, intermediate and countersink drills

All Sweden & Martina drills are made of steel for surgical use with high resistance to corrosion and wear. The extreme accuracy of design and production allows use completely free from vibrations and oscillations.

Precision drill: very sharp and precise, it facilitates the opening of the implant site especially in the case of very hard cortical bone.

Intermediate drills: the shape with progressive diameter of the 2 intermediate drills allows gradual expansion of the bone when using a drill with a diameter much larger than the previous one, so as to reduce bone stress to a minimum.

Pilot drill: the different heights of the laser markings allow better visibility in the surgical field and greater ease of recognition of the different depths during use.

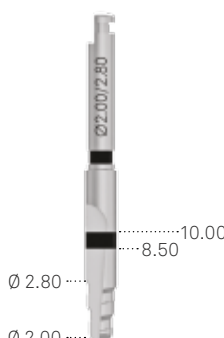
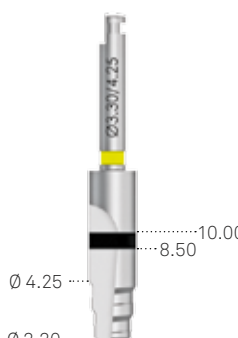
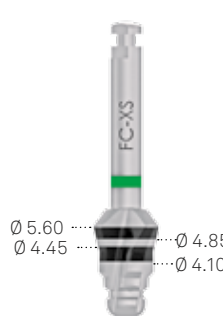

Countersink drill: ideal for preparing the coronal part of the site in the case of implants with a prosthetic platform wider than the diameter of the spires.

initial drill, intermediate drills and countersink drill				kit
FS-230 precision drill  4.80	FG-200/280XS intermediate drill \varnothing 2.00 - 2.80 mm  10.00 8.50 \varnothing 2.80 \varnothing 2.00	FG-330/425XS intermediate drill \varnothing 3.30 - 4.25 mm  10.00 8.50 \varnothing 4.25 \varnothing 3.30	FC-XS countersink drill  \varnothing 5.60 \varnothing 4.45 \varnothing 4.85 \varnothing 4.10	ZPREMIUM-INT ZAONEBOX-INT

pilot drill and relative stops							kit
FPT*-200-LXS pilot drill  19.30 0.58	STOP**-200-070 pilot drill stop 7.00 mm	STOP**-200-085 pilot drill stop 8.50 mm	STOP**-200-100 pilot drill stop 10.00 mm	STOP**-200-115 pilot drill stop 11.50 mm	STOP**-200-130 pilot drill stop 13.00 mm	STOP**-200-150 pilot drill stop 15.00 mm	ZPREMIUM-INT ZAONEBOX-INT

Lt: Total length of the working part, including the tip.

Lp: Length of the tip. This measurement must be calculated in addition to the length of the preparation hole.

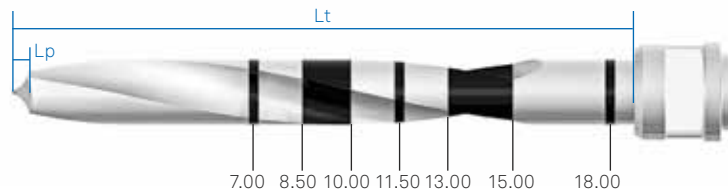

Please note: The initial drills and the final drills, shown on the following page) always make a hole longer than the implant that is to be inserted. The oversizing (Lp) is equal to the height of the tip of the drill that is being used. See drawing above.











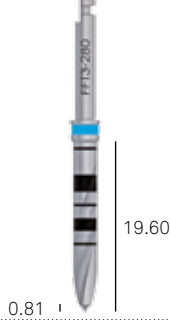
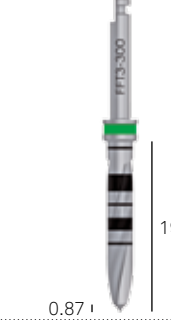
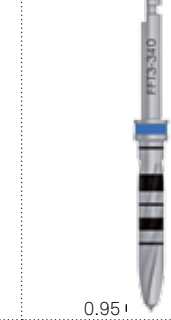
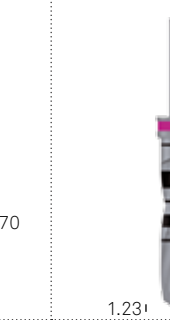





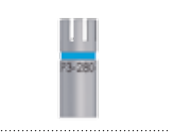

* The abbreviations FPT and FFT are followed by a number (2, 3) indicating the length of the drill shank: 2 indicates a length of 12.50 mm, 3 indicates a length of 14.00 mm. All the STOP2 and STOP3* are functional to any of these batches.

** The word STOP is followed by a number indicating the revision of the accessory. The stops are included only in the surgical kits ZPREMIUM-INT.

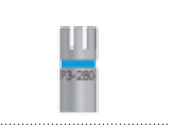
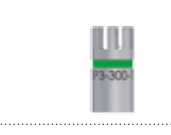
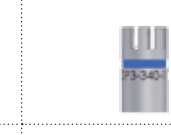
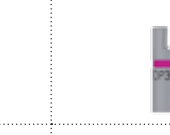
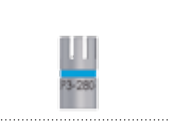
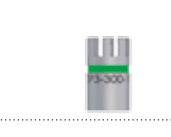
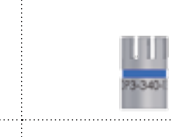
Final drills and stops

Also made of steel for surgical use with high resistance to corrosion and wear, Premium final drills present a number of cutting edges proportional to the hole diameter, so as to allow a continuous and homogeneous cutting movement and greater instrument stability during operation. All this enables high-precision implant preparations to be obtained, with consequent ease in inserting the implant.



implant Ø	Ø 3.30 mm	Ø 3.80 mm	Ø 4.25 mm	Ø 5.00 mm	kit
drills	FFT*-280-LXS 	FFT*-300-LXS 	FFT*-340-LXS 	FFT*-425-LXS 	ZPREMIUM-INT ZAONEBOX-INT
stop	STOP*-280-070 	STOP*-300-070 	STOP*-340-070 	STOP*-425-070 	ZPREMIUM-INT ZAONEBOX-INT
	STOP*-280-085 	STOP*-300-085 	STOP*-340-085 	STOP*-425-085 	ZPREMIUM-INT ZAONEBOX-INT
	STOP*-280-100 	STOP*-300-100 	STOP*-340-100 	STOP*-425-100 	ZPREMIUM-INT ZAONEBOX-INT
	STOP*-280-115 	STOP*-300-115 	STOP*-340-115 	STOP*-425-115 	ZPREMIUM-INT ZAONEBOX-INT
	STOP*-280-130 	STOP*-300-130 	STOP*-340-130 	STOP*-425-130 	ZPREMIUM-INT ZAONEBOX-INT
	STOP*-280-150 	STOP*-300-150 	STOP*-340-150 	STOP*-425-150 	ZPREMIUM-INT ZAONEBOX-INT

Please note: The drills always make a hole that is longer than the implant to be inserted. The oversizing (Lp) is equal to the height of the tip of the drill that is being used (see drawing on page 25 for the key).

* The abbreviations FFT and STOP are followed by a number (2, 3) indicating the length of the drill shank: 2 indicates a length of 12.50 mm, 3 indicates a length of 14.00 mm. All the STOP2 and STOP3 are functional to any of these batches.

Drills for distal sectors

As an option, shorter drills are available that are very practical in distal sectors with limited oral opening. They come in a wide range of diameters and are also useful for preparations in extremely compact bone where, in the most coronal portion, you want to widen the preparation diameter by 0.20 mm with respect to the size of the standard drills to facilitate the insertion of the implants. On the other hand, in low-density bone they can be used to under-prepare the implant site so as to obtain optimum primary stability.

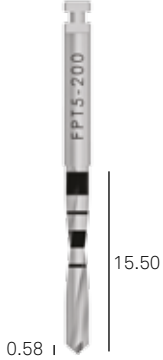
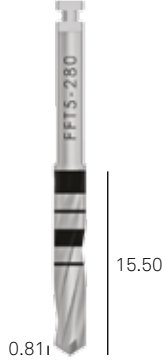
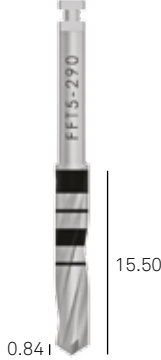
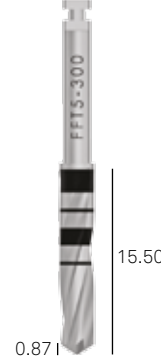
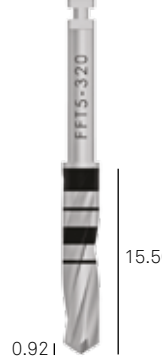

Ø 2.00 mm	Ø 2.80 mm	Ø 2.90 mm	Ø 3.00 mm	Ø 3.20 mm
FPT5-200-LXS cylindrical drill Ø 2.00 mm 	FFT5-280-LXS cylindrical drill Ø 2.80 mm 	FFT5-290-LXS cylindrical drill Ø 2.90 mm 	FFT5-300-LXS cylindrical drill Ø 3.00 mm 	FFT5-320-LXS cylindrical drill Ø 3.20 mm 

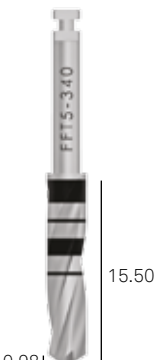
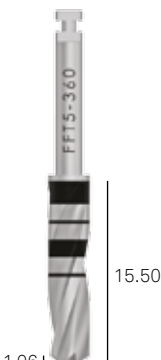
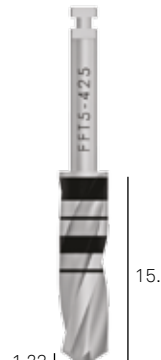
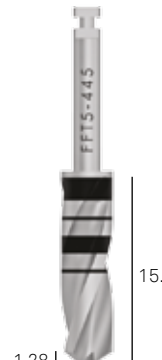
Ø 3.30 mm	Ø 3.40 mm	Ø 3.60 mm	Ø 4.25 mm	Ø 4.45 mm
FFT5-330-LXS cylindrical drill Ø 3.30 mm 	FFT5-340-LXS cylindrical drill Ø 3.40 mm 	FFT5-360-LXS cylindrical drill Ø 3.60 mm 	FFT5-425-LXS cylindrical drill Ø 4.25 mm 	FFT5-445-LXS cylindrical drill Ø 4.45 mm 

* The drills for distal sectors are without irrigation and are not included in any surgical kit. They cannot be used with depth stops.

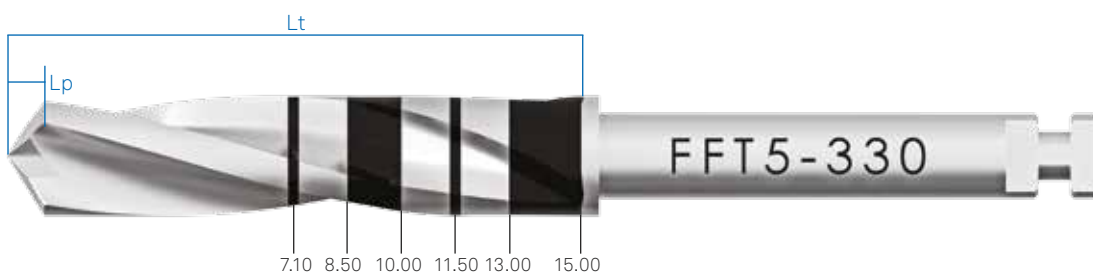

Please note: The drills always make a hole that is longer than the implant to be inserted. The oversizing (Lp) is equal to the height of the tip of the drill that is being used. See drawing above.

Osteotomes

A set of osteotomes made of steel for surgical use is available, useful for maxillary sinus floor expansion and lift protocols via the crestal bone. The particular design of the tips allows the creation of particularly precise sites even after the compacting of very spongy bone matrix.

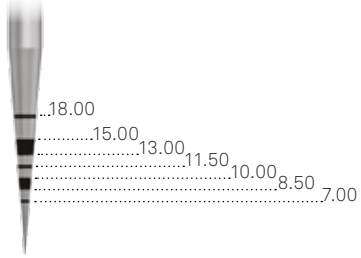
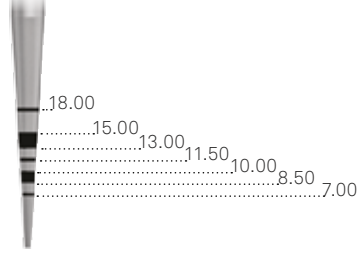
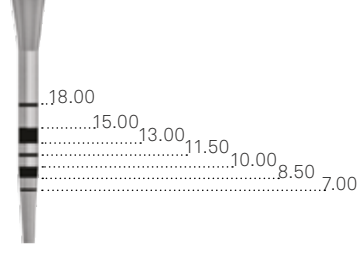
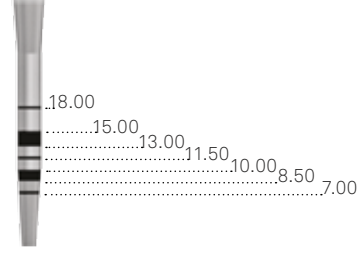
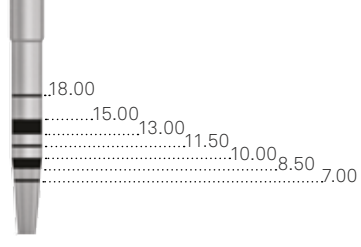
description	code
Osteotome Ø 0.20, flat tip	E-OS-020-PP 
Osteotome Ø 0.90, flat tip	E-OS-090-PP 
Osteotome Ø 1.60, concave tip	E-OS-160-PC 
Osteotome Ø 2.00, concave tip	E-OS-200-PC 
Osteotome Ø 2.40, concave tip	E-OS-240-PC 

The osteotomes are not included in any kit. They are to be ordered separately.

Bone taps

Bone tap with hexagonal attachment: for use with the torque-control ratchet.

Bone tap with right angle attachment: for greater control of the inserting axis and more uniform preparation.

Short bone tap: for use with the torque-control ratchet, it is very useful in distal sectors.



implant diameter	Ø 3.30 mm	Ø 3.80 mm	Ø 4.25 mm	Ø 5.00 mm	kit
bone taps with hexagonal attachment	A-MS-330 	A-MS-380 	A-MS-425 	A-MS-500 	ZPREMIUM-INT
bone taps with right angle attachment	A-MS-330-CA 	A-MS-380-CA 	A-MS-425-CA 	A-MS-500-CA 	ZAONEBOX-INT
short bone taps	A-MSC-330 	A-MSC-380 	A-MSC-425 	A-MSC-500 	-

Please note: short bone taps are not included in any surgical kit, they are available as options.

Additional instruments

All the additional instruments for Premium implants, made of steel for surgical use, have been designed to offer maximum ergonomics and ease of use. All the instruments have a laser-marked code for easy identification of the pieces. All the instruments are available individually as spare parts.







Easy Insert drivers: The particular geometry of the hexagon helps limit sticking and prevents deformations in the implant connection.







Steel drivers: Solid help for removing implants.

Parallelism pins: It is always advisable to check the preparation axis of surgical sites.



Carriers and drivers for implants

description	code	kit
Short driver, with right angle shank, for Premium implants Ø 3.30 and Ø 3.80 mm	EASYC2-EX230-CA 	ZPREMIUM-INT ZAONEBOX-INT
Long driver, with right angle shank, for Premium implants Ø 3.30 and Ø 3.80 mm	EASYL2-EX230-CA 	ZPREMIUM-INT ZAONEBOX-INT
Short driver with connector for torque-control ratchet, for Premium implants Ø 3.30 and Ø 3.80 mm	EASY2-EX230-EX 	ZPREMIUM-INT ZAONEBOX-INT
Short driver, with right angle shank, for Premium implants Ø 4.25 and Ø 5.00 mm	EASYC2-EX250-CA 	ZPREMIUM-INT ZAONEBOX-INT
Long driver, with right angle shank, for Premium implants Ø 4.25 and Ø 5.00 mm	EASYL2-EX250-CA 	ZPREMIUM-INT ZAONEBOX-INT
Short driver with connector for torque-control ratchet, for Premium implants Ø 4.25 and Ø 5.00 mm	EASY2-EX250-EX 	ZPREMIUM-INT ZAONEBOX-INT

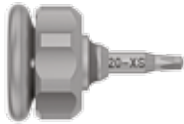

Drivers

description	code	kit
Short driver (hex 2.30)	BC-EX230 	ZPREMIUM-INT ZAONEBOX-INT
Long driver (hex 2.30)	BL-EX230 	ZPREMIUM-INT ZAONEBOX-INT
Short driver (hex 2.50)	BC-EX250 	ZPREMIUM-INT ZAONEBOX-INT
Long driver (hex 2.50)	BL-EX250 	ZPREMIUM-INT ZAONEBOX-INT

Surgical screwdrivers

description	code	kit
Screwdriver for surgical cover screw and connecting screws, digital, extra-short	<p>HSMXS-20-DG</p> 	<p>ZAONEBOX-INT ZSCREW-INT</p>
Screwdriver for surgical cover screw and connecting screws, digital, short	<p>HSM-20-DG</p> 	<p>ZPREMIUM-INT ZAONEBOX-INT ZSCREW-INT</p>
Screwdriver for surgical cover screw and connecting screws, digital, long	<p>HSML-20-DG</p> 	<p>ZPREMIUM-INT ZAONEBOX-INT ZSCREW-INT</p>

Mounters

description	code	kit
Mounter, for Premium implants Ø 3.30 and Ø 3.80 mm	<p>HSMXS-20-DG</p> 	<p>ZPREMIUM-INT ZAONEBOX-INT</p>
Mounter, for Premium implants Ø 4.25 and Ø 5.00 mm	<p>HSM-20-DG</p> 	<p>ZPREMIUM-INT ZAONEBOX-INT</p>

Torque-control ratchet

description	code	kit
Kit composed of a torque control ratchet, which can be used in dynamometric or fixed mode, and accessories for quick torque adjustment and periodic maintenance. The ratchet has torque limits from 10 to 70 Ncm, with adjustment lines at 10-20-25-30-35-50-70 Ncm	CRI5-KIT 	ZPREMIUM-INT ZSCREW-INT

Depth gauge

description	code	kit
Depth gauge	PROF3 	ZPREMIUM-INT





Mounter key stop

description	code	kit
Mounter stop key	CM2 	ZPREMIUM-INT ZAONEBOX-INT







Parallelism pin

description	code	kit
Parallelism pins with one side \varnothing 2.00 and the other \varnothing 2.80 mm	PP-2/28 	ZPREMIUM-INT ZAONEBOX-INT

Prosthetic screwdrivers

description	code	kit
Screwdriver for connecting screws, with hexagonal connector for torque-control ratchet or hand knob, short	HSM-20-EX 	ZPREMIUM-INT ZAONEBOX-INT ZSCREW-INT
Screwdriver for connecting screws, with hexagonal connector for torque-control ratchet or hand knob, long	HSML-20-EX 	ZPREMIUM-INT ZAONEBOX-INT ZSCREW-INT
Screwdriver for connecting screws, with hexagonal connector for torque-control ratchet or hand knob, extra-long	HSMXL-20-EX 	ZPREMIUM-INT ZAONEBOX-INT ZSCREW-INT
Screwdriver for connecting screws, with right angle shank	HSM-20-CA 	ZPREMIUM-INT ZAONEBOX-INT ZSCREW-INT
Screwdriver for ball attachments, with hexagonal connector for torque-control ratchet	BASCC-EX 	ZSCREW-INT
Screwdriver for for straight P.A.D. abutments, with hexagonal connector for torque-control ratchet	AVV2-ABUT 	ZSCREW-INT
Driver for inserting Locator abutment, with hexagonal connector for torque-control ratchet, short	8926-SW 	ZSCREW-INT
Driver for inserting Locator abutment, with hexagonal connector for torque-control ratchet, long	8927-SW 	ZSCREW-INT
Instrument for assembly and maintaining the titanium cap for CAP-TIT-1 ball attachments	AVV-CAP-TIT-1 	ZSCREW-INT

Extensions and fittings

description	code	kit
Extension for bone taps, mounters, drivers and manual drivers, with hexagonal connector for torque-control ratchet	BPM-15 	ZPREMIUM-INT ZAONEBOX-INT
Extension for surgical drills	PROF-CAL2 	ZPREMIUM-INT ZAONEBOX-INT
Mechanical adapter with right angle shank for instruments with hexagonal connector	B-AVV-CA3 	ZPREMIUM-INT ZAONEBOX-INT ZSCREW-INT
Hand knob for bone taps, hand use and right angle drivers	AVV3-MAN-DG 	ZPREMIUM-INT ZAONEBOX-INT ZSCREW-INT
Hand knob for hand use of drivers, bone taps and drivers with right angle shank	AVV-CA-DG-EX 	ZAONEBOX-INT
Carrier for transferring angled abutments into the oral cavity, sterilisable and reusable. Must be secured to the abutments with the screw PAD-VTRAL-140	PAD-CAR 	ZSCREW-INT

Spare O-rings

description	code	kit
Kit with 5 spare o-rings for all accessories with hexagonal connector for dynamometric key	ORING180-088 	-



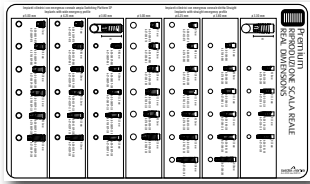

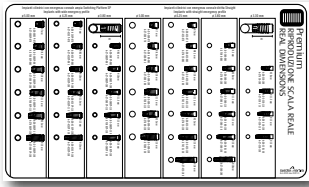



X-ray templates

description	code	kit
<p>X-ray template for Premium implants, real dimensions, dimensions increased by 20% and dimensions increased by 30%</p>	<p>A-L100 A-L120 A-L130</p> 	<p>ZPREMIUM-INT ZAONEBOX-INT</p>



Bone profilers



description	Ø 3.30 mm	Ø 3.80 mm	Ø 4.25 mm	Ø 5.00 mm
Bone profiler with narrow flaring	A-PAD-PS330-S 	A-PAD-PS380-S 	A-PAD-PS425-S 	A-PAD-PS500-S 
Bone profiler with wide flaring	A-PAD-PS330-L 	A-PAD-PS380-L 	A-PAD-PS425-L 	A-PAD-PS500-L 

The bone profilers are not included in any kit. They are to be ordered separately.

All measurements are given in mm, unless indicated otherwise.

Shorty Drilling kit

The implant site of the specific Shorty implants with lengths of 7.00 mm and 8.50 mm can be prepared with the drills contained in the standard surgical kits. However, don't forget that the drills contained in these kits, like all the standard drills, require an over-preparation connected to the measurement of the drill tip (see page 25). The drill tip has a guiding, centring and penetrating function and normally characterises the instrument's ability to move forward, determining its efficiency. For this reason, even though it limits the choice of the preparation length, the drill tip is a normal aspect of traditional surgical protocols. On the other hand, the choice of a short implant is generally connected to the lack of available bone height in the implant site, so it would be desirable not to have to engage a working thickness with the tip of the drill, but instead to lodge a longer implant. For this reason, a drilling kit was created for preparing the Shorty implant sites of the Premium system, in heights of 7.00 mm, and 8.50 mm with very short tip, where a portion of over-preparation is not deemed necessary (see page 25). For example, to insert an implant of 7.00 mm using the Shorty drills, an actual hole of 7.00 mm will be made, and not 7.00 mm plus the portion of over-preparation.

The Shorty drills allow dedicating the entire bone available to lodging the implant, without any waste. Moreover, the Shorty drills have the advantage, compared to traditional drills, of being shorter than the standard drills (24.85 mm instead of 35.00 mm).



This important feature makes it possible to use these instruments even in case of difficult to reach distal sectors or small oral openings.



The kits contain two short parallelism pins, which are very handy in distal sectors.

The colour codes of the implant diameters facilitate the choice of the instruments.

All the instruments in the Shorty Drilling kit are also available individually as spare parts.





description	code
Complete drilling kit for short implants	ZSHORTY-INT 
Empty tray in Radel	SHORTY-KIT-IN 
Kit with 5 spare silicon supports for surgical trays, for drills or instruments with right angle shanks	GROMMET-CA-1 





Please note: remember that the drills in the Shorty Drilling kit do not over-prepare the surgical site. The working lengths include the portion related to the conical tip of the drill.

Important warning

The Shorty Drilling kit is a kit of **only** drills, which also contains two parallelism pins. However, it is not a complete kit; to insert short implants the instruments in the standard surgical kit are required (ratchet, drivers, etc.).

Instruments contained in the Shorty Drilling kit

Shorty pilot drill	Shorty pilot drill stops		
<p>FPS-200 Shorty pilot drill</p> 	<p>STOPS-200-050* 5.00 mm stop for Shorty pilot drill</p> 	<p>STOPS-200-060* 6.00 mm stop for Shorty pilot drill</p> 	<p>STOPS-200-070 7.00 mm stop for Shorty pilot drill</p> 

description	diameter	code	
Short guide drill	2.00/2.50/3.00	FGS-200/300	
Short guide drill	3.40/3.80/4.25	FGS-340/425	
Short guide drill	4.25/4.80/5.40	FGS-425/540*	
Parallelism pin for short implants, with depth lines at 5.00, 6.00 and 7.00 mm	2.00/3.00	PPS-2/3	

* The Drilling kit includes also drills and stops, not related to Premium system.

connection	Ø 3.80 mm	Ø 4.25 mm	Ø 5.00 mm	Ø 6.00 mm
drill	FFS-300  24.85	FFS-340  24.85	FFS-425  24.85	FFS-540*  24.85
stop	STOPS-300-050 	STOPS-340-050 	STOPS-425-050 	STOPS-540-050* 
	STOPS-300-060 	STOPS-340-060 	STOPS-425-060 	STOPS-540-060* 
	STOPS-300-070 	STOPS-340-070 	STOPS-425-070 	STOPS-540-070* 

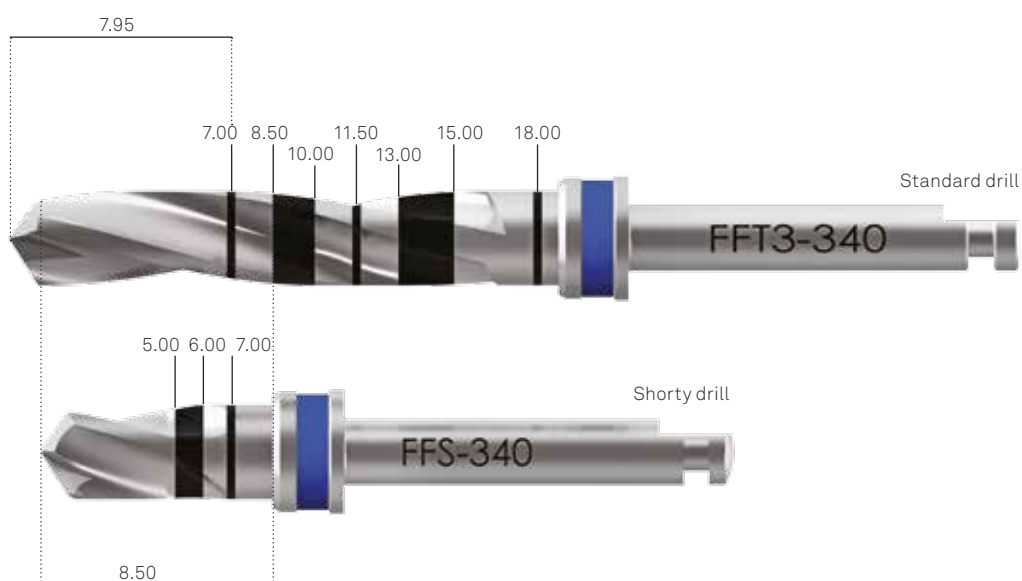

* The Drilling kit includes also drills and stops, not related to Premium system.

Please note: remember that the drills in the Shorty Drilling kit do not over-prepare the surgical site. The working lengths include the portion related to the conical tip of the drill.

All measurements are given in mm, unless indicated otherwise.

Healing abutments

The healing abutments, in Gr. 5 titanium, can be identified by a laser marking that reports the diameter, emergence profile and height. In case of healing abutments with straight emergence profile, the marking only reports the platform diameter and height.

The healing abutments must be tightened at a torque of 10 Ncm, using the HSM series of drivers, the full details and codes of which can be found on page 32.

Healing abutments with straight emergence profile:













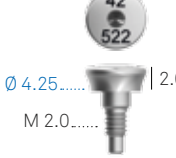





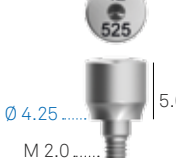
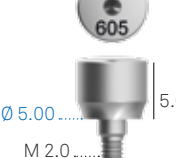

the laser marking, on the side, allows immediate recognition of the connection diameter (38 = 3.80 mm) and of the transgingival height (3 = 3.00 mm).



Guiding cylinder: facilitates centring when inserting the implant.

Healing abutments with anatomical emergence profile:

the laser marking, on the upper surface, shows the connection diameter (50 = 5.00 mm), the maximum crown size (60 = 6.00 mm) and the transgingival height (2 = 2.00 mm).

connection	Ø 3.30 mm	Ø 3.80 mm	Ø 4.25 mm	Ø 5.00 mm
Healing abutments Anatomical emergence profile transgingival H. 2.00 mm	A-TMGR-330-2  Ø 3.30..... 2.00 M 1.8.....	A-TMGR-380-2  Ø 3.80..... 2.00 M 1.8.....	A-TMGR-425-2  Ø 4.25..... 2.00 M 2.0.....	A-TMGR-500-2  Ø 5.00..... 2.00 M 2.0.....
Healing abutments Anatomical emergence profile transgingival H. 3.00 mm	A-TMGR-330-3  Ø 3.30..... 3.00 M 1.8.....	A-TMGR-380-3  Ø 3.80..... 3.00 M 1.8.....	A-TMGR-425-3  Ø 4.25..... 3.00 M 2.0.....	A-TMGR-500-3  Ø 5.00..... 3.00 M 2.0.....
Healing abutments Anatomical emergence profile transgingival H. 5.00 mm	A-TMGR-330-5  Ø 3.30..... 5.00 M 1.8.....	A-TMGR-380-5  Ø 3.80..... 5.00 M 1.8.....	A-TMGR-425-5  Ø 4.25..... 5.00 M 2.0.....	A-TMGR-500-5  Ø 5.00..... 5.00 M 2.0.....
Healing abutments Anatomical emergence profile transgingival H. 7.00 mm	-	A-TMGR-380-7  Ø 3.80..... 7.00 M 1.8.....	A-TMGR-425-7  Ø 4.25..... 7.00 M 2.0.....	A-TMGR-500-7  Ø 5.00..... 7.00 M 2.0.....
Healing abutments Straight emergence profile transgingival H. 2.00 mm	A-TMG-330-2  Ø 3.30..... 2.00 M 1.8.....	A-TMG-380-2  Ø 3.80..... 2.00 M 1.8.....	-	-
Healing abutments Straight emergence profile transgingival H. 3.00 mm	A-TMG-330-3  Ø 3.30..... 3.00 M 1.8.....	A-TMG-380-3  Ø 3.80..... 3.00 M 1.8.....	-	-
Healing abutments Straight emergence profile transgingival H. 5.00 mm	A-TMG-330-5  Ø 3.30..... 5.00 M 1.8.....	A-TMG-380-5  Ø 3.80..... 5.00 M 1.8.....	-	-

Recommended torque for healing abutments: 8-10 Ncm.

All measurements are given in mm, unless indicated otherwise.

Impression and model phase

The components for the impression and the creation of the model are produced with the same machines that make the implants; this ensures a real guarantee of precision from the point of view of tolerance and fidelity in the reproduction of the clinical situation.

The open tray and closed tray transfers are made of Gr. 5 titanium, anodised according to the colour code of the reference platform, facilitating the identification of any different diameters that may be used.

The pull-up transfer is made of radiopaque PEEK to allow checking of the correct insertion in the implant platform.

Open tray transfer: the design of the upper portion guarantees excellent retention and therefore an extremely stable fixing in the impression.



Closed tray transfer: ideal for taking impressions with the closed tray technique, the repositioning face allows the transfer to be put back exactly in the impression material so as to reproduce the orientation of the connection precisely.

Implant analog: anodised according to the colour code to facilitate recognition and laboratory phases.

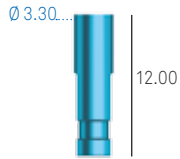

Pull-up transfer: the connection with tabs clicks into the implant connecting hexagon, without requiring a screw.

Analogs

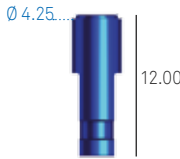
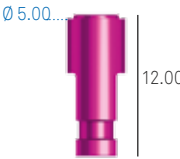
connection	Ø 3.30 mm	Ø 3.80 mm	Ø 4.25 mm	Ø 5.00 mm
Analogs	A-ANA-330 	A-ANA-380 	A-ANA-425 	A-ANA-500 

Pull-up transfers

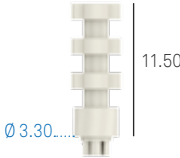
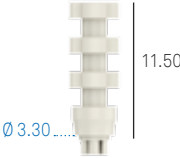
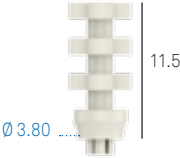
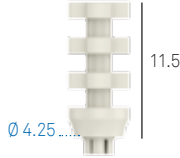
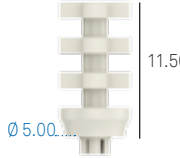
connection	Ø 3.30 mm	Ø 3.80 mm	Ø 4.25 mm	Ø 5.00 mm
Pull-up transfers in radiopaque PEEK straight emergence profile	A-TRAP-330 	-	-	-
Pull-up transfers in radiopaque PEEK Anatomical emergence profile	A-TRARP-330 	A-TRARP-380 	A-TRARP-425 	A-TRARP-500 

Important warning

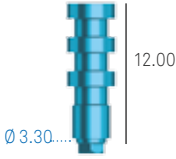
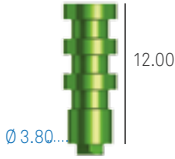
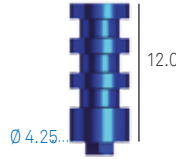
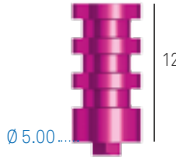
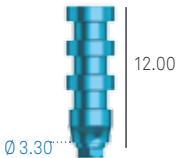
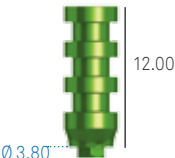
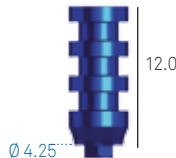
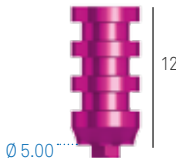
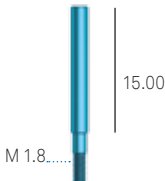
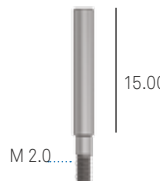
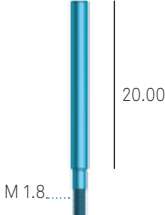
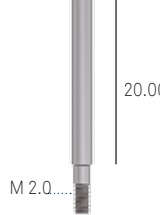

As the pull-up transfers are made of polymer material, to guarantee precision it is recommended to use new transfers for taking each impression.

Open tray transfers

connection	Ø 3.30 mm	Ø 3.80 mm	Ø 4.25 mm	Ø 5.00 mm
Open tray transfers Straight emergence profile Connecting screw included	A-TRA-330  Ø 3.30... 12.00	A-TRA-380  Ø 3.80... 12.00	A-TRA-425  Ø 4.25... 12.00	A-TRA-500  Ø 5.00... 12.00
Open tray transfers Anatomical emergence profile Connecting screw included	A-TRAR-330  Ø 3.30... 12.00	A-TRAR-380  Ø 3.80... 12.00	A-TRAR-425  Ø 4.25... 12.00	A-TRAR-500  Ø 5.00... 12.00
Single pack Connecting screws for open tray transfers Supplied with the transfers, it can also be ordered separately as a spare	VTRA2-180-15  M 1.8... 15.00	Use VTRA2-180-15	VTRA2-200-15  M 2.0... 15.00	Use VTRA2-200-15
Single pack Connecting screws for open tray transfer, length 20.00 mm, to be ordered as a spare	VTRA2-180-20  M 1.8... 20.00	Use VTRA2-180-20	VTRA2-200-20  M 2.0... 20.00	Use VTRA2-200-20

Recommended torque for transfer screws: 8-10 Ncm.

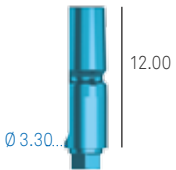
Closed tray transfers

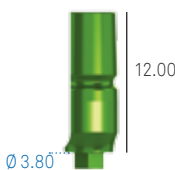
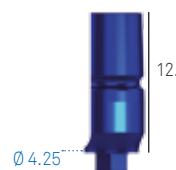
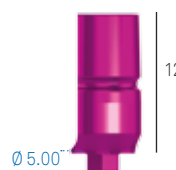
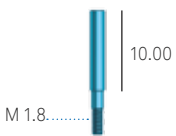
connection	Ø 3.30 mm	Ø 3.80 mm	Ø 4.25 mm	Ø 5.00 mm
Closed tray transfers Straight emergence profile Connecting screw included	A-TRAS-330  <p>Ø 3.30 mm 12.00</p>	-	-	-
Closed tray transfers Anatomical emergence profile Connecting screw included	A-TRARS-330  <p>Ø 3.30 mm 12.00</p>	A-TRARS-380  <p>Ø 3.80 mm 12.00</p>	A-TRARS-425  <p>Ø 4.25 mm 12.00</p>	A-TRARS-500  <p>Ø 5.00 mm 12.00</p>
Single pack Connecting screws for open tray transfers Supplied with the transfers, it can also be ordered separately as a spare	VTRA2-180-10  <p>M 1.8 mm 10.00</p>	Use VTRA2-180-10	VTRA2-200-10  <p>M 2.0 mm 10.00</p>	Use VTRA2-200-10

Recommended torque for transfer screws: 8-10 Ncm.

All measurements are given in mm, unless indicated otherwise.

SIMPLE temporary posts

The SIMPLE prosthetic protocol calls for practical and simple solutions to create the temporary posts. The temporary posts can be used in a conventional way after the bone healing period, or immediately after surgical insertion of the implants, if conditions exist for immediate loading. They can also be used as an alternative to the traditional healing abutments for reconditioning the soft tissues, depending on the prosthetic protocol that is adopted.





PEEK is an extremely resistant and highly biocompatible polymer, easy to drill even in the dentist's chair. The titanium base, with a straight or anatomical emergence profile, guarantees maximum connection precision. They are ideal for supporting cement-retained single crowns.

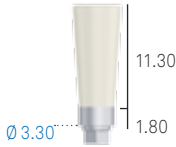
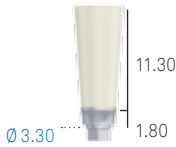
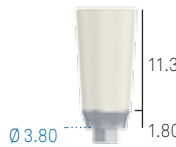
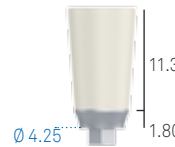
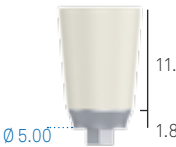
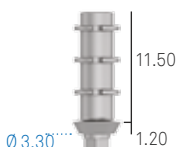
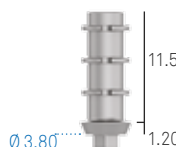
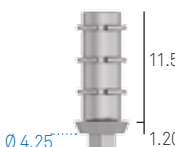
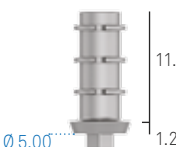
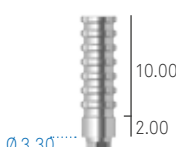
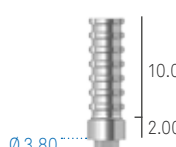
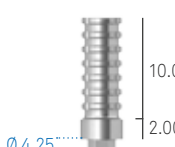
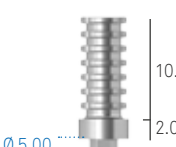
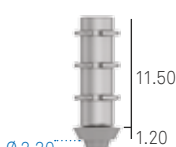
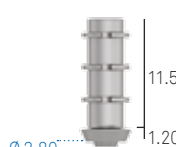
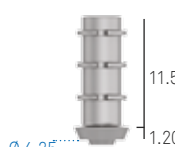
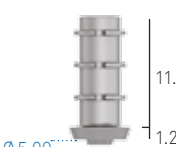
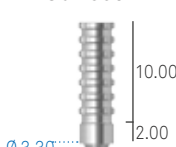
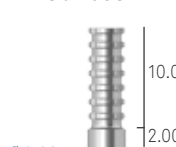

The versions with the widest flaring of the transgingival profile, adaptable to any anatomy by drilling, simplify the immediate aesthetic conditioning of the mucosa.

The centring **cone** of temporary posts without repositioning hexagon and the narrow transgingival profile considerably facilitate the creation of multiple temporary structures to be screwed directly onto the implants even in the presence of significant parallelism defects.

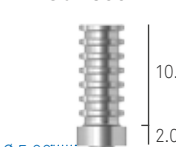
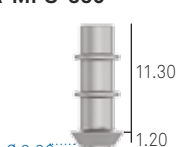
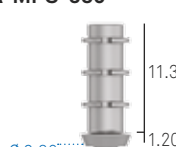
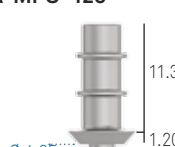
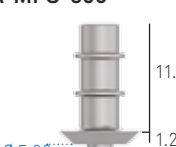
The **hexagon** which guarantees the non-rotational aspect makes this post perfect for making single screwed temporary posts.

connection	Ø 3.30 mm	Ø 3.80 mm	Ø 4.25 mm	Ø 5.00 mm
SIMPLE temporary posts in PEEK with a Gr. 5 titanium base Repositionable Straight emergence profile Connecting screw included	A-MPSC-330 	-	-	-
SIMPLE temporary posts in PEEK with a Gr. 5 titanium base Repositionable Anatomical emergence profile Connecting screw included	A-MPSCR-330 	A-MPSCR-380 	A-MPSCR-425 	A-MPSCR-500 
SIMPLE temporary posts in Gr. 5 titanium Repositionable Anatomical emergence Connecting screw included	A-MPSA-330-EX 	A-MPSA-380-EX 	A-MPSA-425-EX 	A-MPSA-500-EX 
SIMPLE temporary posts in Gr. 5 titanium Repositionable Straight emergence profile	A-MPSCI-330-EX 	A-MPSCI-380-EX 	A-MPSCI-425-EX 	A-MPSCI-500-EX 
SIMPLE temporary posts in Gr. 5 titanium Non-repositionable Anatomical emergence profile Connecting screw included	A-MPSA-330 	A-MPSA-380 	A-MPSA-425 	A-MPSA-500 
SIMPLE temporary posts in Gr. 5 titanium Non-repositionable Straight emergence profile	A-MPSCI-330 	A-MPSCI-380 	A-MPSCI-425 	A-MPSCI-500 
SIMPLE temporary aesthetic posts in Gr. 5 titanium Non-repositionable Wide emergence profile Connecting screw included	A-MPS-330 	A-MPS-380 	A-MPS-425 	A-MPS-500 
Single pack Pack of 10 pieces Connecting screw for posts Supplied with the temporary posts, it can also be ordered separately as a spare	VM2-180 VM2-180-10 	Use VM2-180	VM2-200 VM2-200-10 	Use VM2-200

See PEEK technical characteristics on page 94.

Recommended torque for connecting screws: 20-25 Ncm.

Important warning

It is recommended always to use test screws for the laboratory phases and to keep the new screw supplied for the final fastening in the mouth.

All measurements are given in mm, unless indicated otherwise.

Pre-made posts

Made of Gr. 5 titanium, these posts are subjected to a controlled passivation process that changes their surface colour: the result is a characteristic golden pale yellow colour. This colour is obtained through an oxidation process and, therefore, there is no type of coating, so it ensures the use of a highly biocompatible surface.

The direct screw-retained posts have a well on the head into which is inserted the standard screwdriver of the system for screwing on the posts (family HSM -... see page 32 for the codes).

Angled posts: with a passing screw they offer 15° or 25° angles.

Colour: The golden colour makes them ideal for prosthetic rehabilitations of particular aesthetic importance.



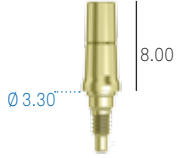
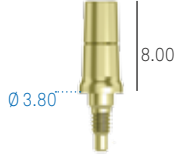
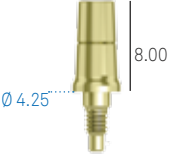
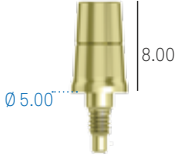

Solid one-piece abutments: they are ideal for securing titanium stabilisation bars inside the oral cavity for rehabilitations with immediate loading because this technique guarantees the absolute immobility of the prosthesis and implant. They are also useful for cementing multiple prostheses on parallel implants.

Hexagon: guarantees repositioning and the non-rotational aspect; this type of post is therefore indicated for making single structures.

connection	Ø 3.30 mm	Ø 3.80 mm	Ø 4.25 mm	Ø 5.00 mm
Solid one-piece abutments Non-repositionable	A-MDAD-330 	A-MDAD-380 	A-MDAD-425 	A-MDAD-500 

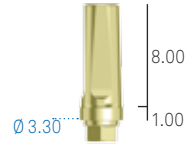
Recommended torque: 25-30 Ncm.







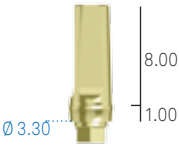
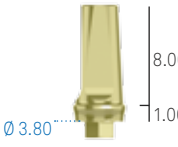
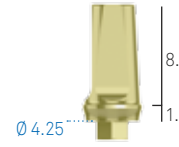
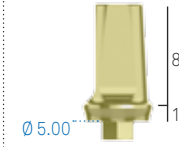
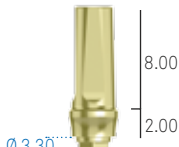
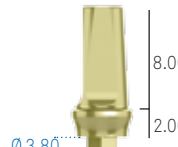
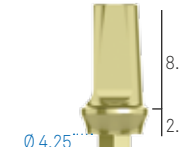

connection	Ø 3.30 mm	Ø 3.80 mm	Ø 4.25 mm	Ø 5.00 mm
Pre-made straight posts Repositionable Straight emergence profile Transgingival height 1.00 mm Connecting screw included	A-MD-330-1 	A-MD-380-1 	-	-
Pre-made straight posts Repositionable Straight emergence profile Transgingival height 2.00 mm Connecting screw included	A-MD-330-2 	A-MD-380-2 	-	-
Pre-made straight posts Repositionable Straight emergence profile Transgingival height 4.00 mm Connecting screw included	A-MD-330-4 	A-MD-380-4 	-	-
Single pack Pack of 10 pieces Connecting screw Supplied with the posts, it can also be ordered separately as a spare	VM2-180 VM2-180-10 	Use VM2-180	-	-

Important warning

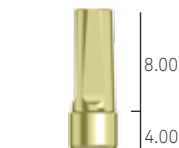

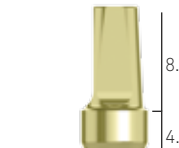
It is recommended always to use test screws for the laboratory phases and to keep the new screw supplied for the final fastening in the mouth.

Recommended torque for connecting screws: 20-25 Ncm.

All measurements are given in mm, unless indicated otherwise.

connection	Ø 3.30 mm	Ø 3.80 mm	Ø 4.25 mm	Ø 5.00 mm
<p>Pre-made straight posts Repositionable Anatomical emergence profile Transgingival height 1.00 mm Connecting screw included</p>	<p>A-MDR-330-1</p> 	<p>A-MDR-380-1</p> 	<p>A-MDR-425-1</p> 	<p>A-MDR-500-1</p> 
<p>Pre-made straight posts Repositionable Anatomical emergence profile Transgingival height 2.00 mm Connecting screw included</p>	<p>A-MDR-330-2</p> 	<p>A-MDR-380-2</p> 	<p>A-MDR-425-2</p> 	<p>A-MDR-500-2</p> 
<p>Pre-made straight posts Repositionable Anatomical emergence profile Transgingival height 4.00 mm Connecting screw included</p>	<p>A-MDR-330-4</p> 	<p>A-MDR-380-4</p> 	<p>A-MDR-425-4</p> 	<p>A-MDR-500-4</p> 
<p>Single pack Pack of 10 pieces</p> <p>Connecting screw Supplied with the posts, it can also be ordered separately as a spare</p>	<p>VM2-180 VM2-180-10</p> 	<p>Use VM2-180</p>	<p>VM2-200 VM2-200-10</p> 	<p>Use VM2-200</p>

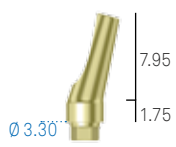
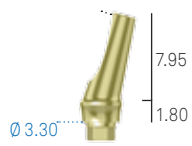
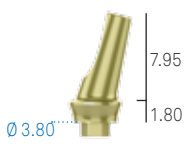
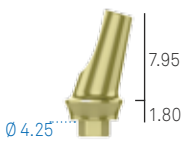
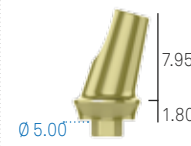
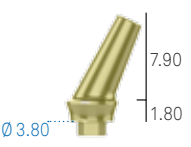
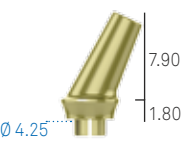
Recommended torque for connecting screws: 20-25 Ncm.

connection	Ø 3.30 mm	Ø 3.80 mm	Ø 4.25 mm	Ø 5.00 mm
Pre-made posts angled at 15° Repositionable Straight emergence profile Transgingival height 1.75 mm Connecting screw included	A-MA15-330 	-	-	-
Pre-made posts angled at 15° Repositionable Anatomical emergence profile Transgingival height 1.80 mm Connecting screw included	A-MAR15-330 	A-MAR15-380 	A-MAR15-425 	A-MAR15-500 
Pre-made posts angled at 25° Repositionable Anatomical emergence profile Transgingival height 1.80 mm Connecting screw included	-	A-MAR25-380 	MAR25-425 	-
Single pack Pack of 10 pieces Connecting screw for posts Supplied with the posts, it can also be ordered separately as a spare	VM2-180 VM2-180-10 	Use VM2-180	VM2-200 VM2-200-10 	Use VM2-200

Important warning

It is recommended always to use test screws for the laboratory phases and to keep the new screw supplied for the final fastening in the mouth.

Recommended torque for connecting screws: 20-25 Ncm.

All measurements are given in mm, unless indicated otherwise.







Standard millable posts

They are made of Gr. 5 titanium and are able to respond to complex anatomical requirements in terms of both narrow prosthetic spaces and parallel implants.

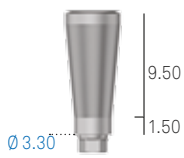
Straight millable posts, with their characteristic profile in the shape of an inverted cone, are suitable for angles of up to 10° and small profiles.

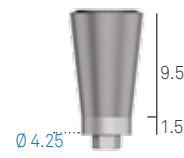
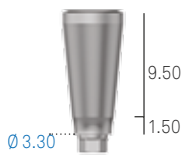
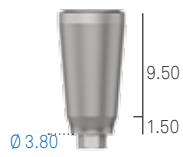

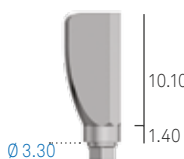
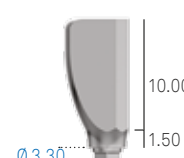
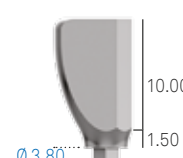
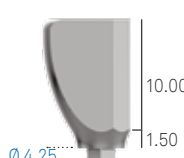
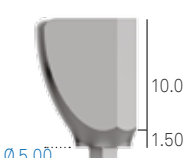
Pre-cut posts, allow very pronounced angles to be reached, up to 25°, limiting the time needed to reduce them by milling.

connection	Ø 3.30 mm	Ø 3.80 mm	Ø 4.25 mm	Ø 5.00 mm
Straight millable posts Repositionable Straight emergence profile Connecting screw included	A-MF-330 	A-MF-380 	A-MF-425 	-
Straight millable posts Repositionable Anatomical emergence profile Connecting screw included	A-MFR-330 	A-MFR-380 	A-MFR-425 	A-MFR-500 
Pre-angled millable posts Repositionable Straight emergence profile Connecting screw included	A-MFP-330 	-	-	-
Pre-angled millable posts Repositionable Anatomical emergence profile Connecting screw included	A-MFPR-330 	A-MFPR-380 	A-MFPR-425 	A-MFPR-500 
Single pack Pack of 10 pieces	VM2-180 VM2-180-10	Use VM2-180	VM2-200 VM2-200-10	Use VM2-200
Connecting screw for posts Supplied with the temporary posts, it can also be ordered separately as a spare	 M 1.8		 M 2.0	

Important warning

It is recommended always to use test screws for the laboratory phases and to keep the new screw supplied for the final fastening in the mouth.

Recommended torque for connecting screws: 20-25 Ncm.

All measurements are given in mm, unless indicated otherwise.

Millable posts



Alongside the traditional prosthetic protocols, Sweden & Martina has developed innovative solutions in collaboration with distinguished professionals and universities. Among these, the SIMPLE Technique allows perfect conditioning of the mucosa starting with temporary aesthetic posts (see page 46) and uses a millable post with large dimensions for making a primarily custom-made final prosthesis.

Instead the Interceptiv Technique uses posts characterised by two wide faces, which guarantee unequivocal repositioning on a model developed from an impression taken directly on the posts.

The **millable posts** for the Interceptiv Technique have an emergence profile that simplifies the taking of the impression with closed tray technique, while the two wide faces guarantee unequivocal repositioning.

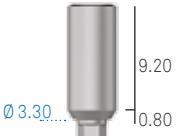
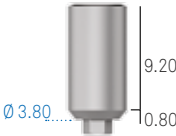
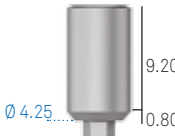
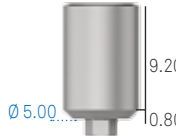
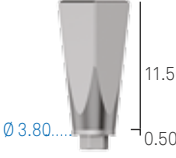
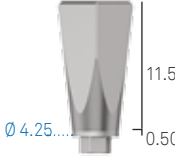
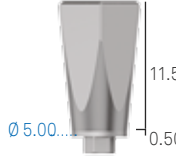

SIMPLE millable posts have a very wide emergence profile which can be adapted to any anatomy obtained with SIMPLE temporary aesthetic posts in the immediate conditioning phase.

connection	Ø 3.30 mm	Ø 3.80 mm	Ø 4.25 mm	Ø 5.00 mm
Millable posts for SIMPLE technique Repositionable Very wide emergence profile Connecting screw included	A-MFS-330 	A-MFS-380 	A-MFS-425 	A-MFS-500 
Millable posts for interceptive technique Repositionable Connecting screw included	-	A-MFTI-380 	A-MFTI-425 	A-MFTI-500 
Single pack Pack of 10 pieces Connecting screw for posts Supplied with the posts, it can also be ordered separately as a spare	VM2-180 VM2-180-10 	Use VM2-180	VM2-200 VM2-200-10 	Use VM2-200

Important warning

It is recommended always to use test screws for the laboratory phases and to keep the new screw supplied for the final fastening in the mouth.

Recommended torque for connecting screws: 20-25 Ncm.

All measurements are given in mm, unless indicated otherwise.

B.O.P.T. prosthesis

According to the principles of the B.O.P.T. technique (Biologically Oriented Preparation Technique) a simplified line has been developed that allows you to have only two posts for Premium platforms. This is possible thanks to the particular design of the connection, different from the classic connection, which allows it to rest safely on the platform of the centring collar.



Premium Ø 3.30



Premium Ø 3.80

..... The same B.O.P.T. millable post **A-MEFL-330** with a 2.30 mm hexagon is used on Premium implants with Ø 3.30 and 3.80 mm.

The same B.O.P.T. millable post **A-MEFL-425** with a 2.50 mm hexagon is used on Premium implants with Ø 4.25 and 5.00 mm.







.....

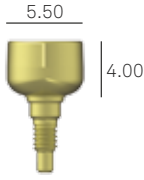
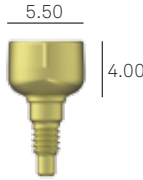

Premium Ø 4.25



Premium Ø 5.00

prosthetic component hex	2.30 mm	2.50 mm
for implants	Ø 3.30 and 3.80 mm	Ø 4.25 and 5.00 mm
B.O.P.T. healing abutment	A-TMG-MEFL-330  5.50 4.00	A-TMG-MEFL-425  5.50 4.00
B.O.P.T. millable post in titanium Connecting screw included	A-MEFL-330  5.50 10.10	A-MEFL-425  5.50 10.10
B.O.P.T. cap for taking the impression Connecting screw included	CAP-MEFL-5 	Use CAP-MEFL-5
Single pack Pack of 10 pieces Connecting screws for B.O.P.T. posts Supplied with the posts, it can also be ordered separately as a spare	VM2-180 VM2-180-10 	VM2-200 VM2-200-10 

Recommended torque for connecting screws: 20-25 Ncm.

All measurements are given in mm, unless indicated otherwise.

Castable posts with base in alloy, titanium and cobalt chrome











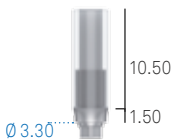
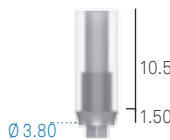
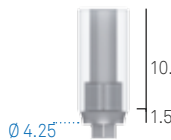

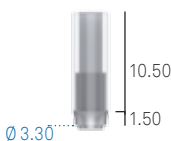
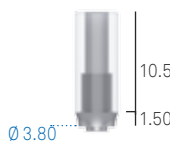
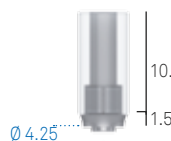
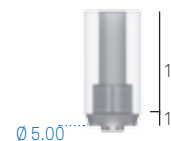
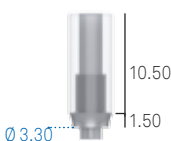
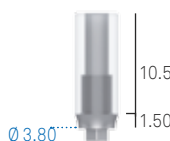
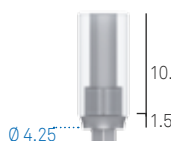
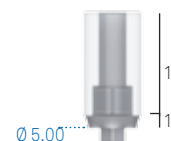

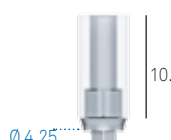
Castable posts with an alloy base combine the simplicity of castable solutions with a base of gold alloy, cobalt chrome or titanium, highly biocompatible materials. The melting point of the above-mentioned alloys is such as to preserve the base against dimensional alterations at the time of overcasting the castable part.

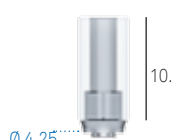

The repositionable version is suitable for creating single elements.

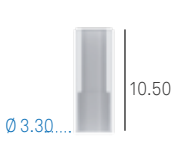
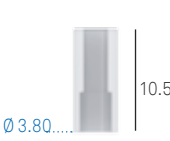
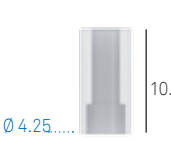
The bases are available in gold alloy, Gr. 5 titanium and cobalt chrome.

.....The non repositionable version presents a cylinder which, when inscribed in the octagon of the connection, guarantees the simple insertion of multiple structures.

connection	Ø 3.30 mm	Ø 3.80 mm	Ø 4.25 mm	Ø 5.00 mm
Castable posts with a pre-made base in gold alloy "1" Repositionable Anatomical emergence profile Connecting screw included	A-UCR-330-EX 	A-UCR-380-EX 	A-UCR-425-EX 	A-UCR-500-EX 
Castable posts with a pre-made base in gold alloy "1" Non-repositionable Anatomical emergence profile Connecting screw included	A-UCR-330 	A-UCR-380 	A-UCR-425 	A-UCR-500 
Castable posts with pre-made base in Titanium Repositionable Anatomical emergence profile Connecting screw included	A-UCTR-330-EX 	A-UCTR-380-EX 	A-UCTR-425-EX 	A-UCTR-500-EX 
Castable posts with pre-made base in cobalt chrome Repositionable Anatomical emergence profile Connecting screw included	A-UCRCO-330-EX 	A-UCRCO-380-EX 	A-UCRCO-425-EX 	A-UCRCO-500-EX 
Castable posts with pre-made base in cobalt chrome Non-repositionable Anatomical emergence profile Connecting screw included	A-UCRCO-330 	A-UCRCO-380 	A-UCRCO-425 	A-UCRCO-500 
Spare castable sleeves for castable posts with alloy base Without connecting screw	A-CCUCR-330 	A-CCUCR-380 	A-CCUCR-425 	A-CCUCR-500 
Single pack Pack of 10 pieces	VM2-180 VM2-180-10	Use VM2-180	VM2-200 VM2-200-10	Use VM2-200
Connecting screw for posts Supplied with the posts, it can also be ordered separately as a spare	M 1.8 		M 2.0 	

Important warning

It is recommended always to use test screws for the laboratory phases and to keep the new screw supplied for the final fastening in the mouth.

See the technical characteristics of titanium, gold alloy and cobalt chrome from page 92.

Recommended torque for connecting screws: 20-25 Ncm.

All measurements are given in mm, unless indicated otherwise.







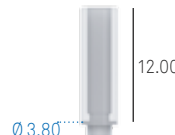

Entirely castable posts

The posts made entirely of PMMA, a resin that does not leave any residue in casting, are produced not by moulding but by turning, like all Sweden & Martina prosthetic components, allowing the respect of micrometric tolerances and enabling a precise connection to be obtained even after the casting process.

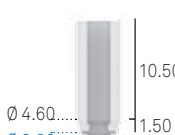
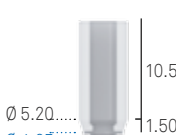
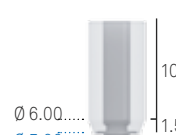

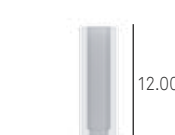
Castable posts: allow maximum ease of modelling.

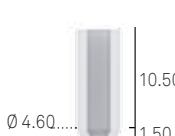
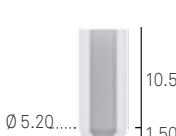
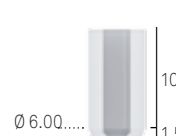

connection	Ø 3.30 mm	Ø 3.80 mm	Ø 4.25 mm	Ø 5.00 mm
Castable posts for casting Repositionable Straight emergence profile Connecting screw included	A-CC-330-EX 	A-CC-380-EX 	-	-
Castable posts for casting Repositionable Anatomical emergence profile Connecting screw included	A-CCR-330-EX 	A-CCR-380-EX 	A-CCR-425-EX 	A-CCR-500-EX 
Castable posts for casting Non-repositionable Straight emergence profile Connecting screw included	A-CC-330 	A-CC-380 	-	-
Castable posts for casting Non-repositionable Anatomical emergence profile Connecting screw included	A-CCR-330 	A-CCR-380 	A-CCR-425 	A-CCR-500 
Single pack Pack of 10 pieces Connecting screw for posts Supplied with the castable posts, it can also be ordered separately as a spare	VM2-180 VM2-180-10 	Use VM2-180	VM2-200 VM2-200-10 	Use VM2-200

Important warning

It is recommended always to use test screws for the laboratory phases and to keep the new screw supplied for the final fastening in the mouth.

See PMMA technical characteristics on page 93.

Recommended torque for connecting screws: 20-25 Ncm.

All measurements are given in mm, unless indicated otherwise.

Prosthesis on intermediate abutments











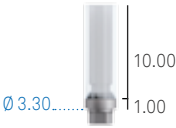
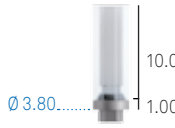
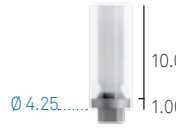

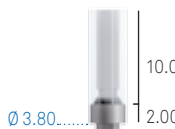
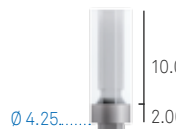

These abutments have a straight emergence profile and are made up of a repositionable titanium base, characterised by a small upper cone with a height of 0.70 mm, the same for all the connection diameters, which allows easy insertion and removal of the over-structures, even in case of slight disparallelism. The abutment is supplied with the castable sleeves for modelling and casting the over-structure and with the passing screw for the "packet" fastening of the over-structure and abutments to the implants. Normally, when these abutments are used, the impression is taken directly on the implants using the transfers. Instead when the titanium base of the abutments is used to make a temporary pots, the impression is transferred to the laboratory with the use of the special transfers and the castable sleeve is sent to the laboratory with the relative connecting screw (option available only for $\varnothing < 4.25$ mm).

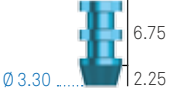
A titanium sleeve is normally used to create the temporary prosthesis, which is supplied complete with the relative connecting screw.

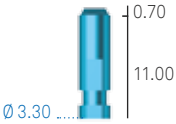
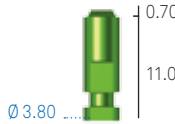
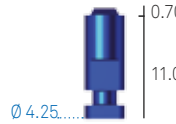
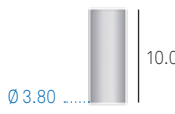

The transfers and the dedicated analogs help to transfer the abutment position to the laboratory.

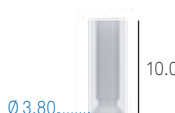
The intermediate abutments have a straight emergence profile.

connection	Ø 3.30 mm	Ø 3.80 mm	Ø 4.25 mm	Ø 5.00 mm
Straight abutments with fixation screw Repositionable Transgingival height 1.00 mm Connecting screw included	A-ABU-330-1 	A-ABU-380-1 	A-ABU-425-1 	A-ABU-500-1 
Straight abutments with fixation screw Repositionable Transgingival Height. 2.00 mm Connecting screw included	A-ABU-330-2 	A-ABU-380-2 	A-ABU-425-2 	A-ABU-500-2 
Connecting screw for abutments Supplied with the abutments, it can also be ordered separately as a spare	A-VABU-180 	Use A-VABU-180	A-VABU-200 	Use A-VABU-200
Open tray transfer for standard abutments Non-repositionable Connecting screw included	A-TRABU-330 	A-TRABU-380 	A-TRABU-425 	-
Single pack Spare screw for abutment transfers Supplied with the transfers, it can also be ordered separately as a spare	A-VTRABU-180 	Use A-VTRABU-180	A-VTRABU-200 	Use A-VTRABU-200
Analogues for standard abutments Non-repositionable Connecting screw included	A-ANABU-330 	A-ANABU-380 	A-ANABU-425 	-
Single pack Sleeves in titanium for abutments Connecting screw included	-	A-CTABU-380-ROT 	A-CTABU-425-ROT 	-
Single pack Spare castable sleeves for abutments Connecting screw not included	A-CCABU-330-ROT 	A-CCABU-380-ROT 	A-CCABU-425-ROT 	A-CCABU-500-ROT 

Important warning

It is recommended always to use test screws for the laboratory phases and to keep the new screw supplied for the final fastening in the mouth.

See PMMA technical characteristics on page 93.

Recommended torque for connecting screws: 20-25 Ncm.

All measurements are given in mm, unless indicated otherwise.

P.A.D. (Disparallel Screwed Prosthesis)

The P.A.D. systematics (Disparallel Screwed Prosthesis) was designed to facilitate the production of multiple screwed prostheses, even in the presence of very divergent implants and disparallel prosthetic emergences.

The P.A.D. angled abutments are the simplest and most predictable solutions for implants positioned in distal saddles with high inclination. The P.A.D. prosthetic system is very versatile, starting from the wide range of straight abutments (available in various transgingival heights of 1.50, 3.00 and 4.00 mm), angled abutments (available with angles of 30° and 17° and transgingival heights of 3.00 and 5.00 mm), and a complete range of components necessary for producing the over-structures (transfers, analogs, sleeves, etc.).

P.A.D. abutments: these all have the same upper cone, angled at 15°, which facilitates the manoeuvres of inserting and removing multiple screwed prostheses.





The upper cone allows further repositioning of the prosthetic structure by 15° on each side, which in the case of angled P.A.D. abutments are added to the angle of 17° or 30°. This characteristic allows easy management of disparallelism of up to 45° on each side.



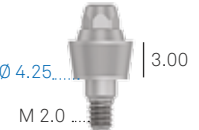



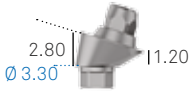
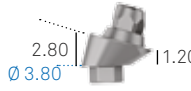
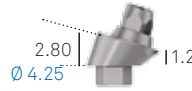
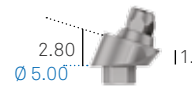
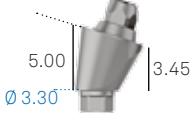
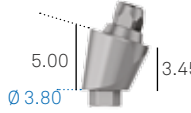
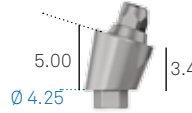
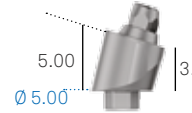

Straight P.A.D.

connection	Ø 3.30 mm	Ø 3.80 mm	Ø 4.25 mm	Ø 5.00 mm
Straight P.A.D. abutments Direct screw-retained Transgingival height 1.50 mm	A-PAD-AD330-15 	A-PAD-AD380-15 	A-PAD-AD425-15 	A-PAD-AD500-15 
Straight P.A.D. abutments Direct screw-retained Transgingival height 3.00 mm	A-PAD-AD330-30 	A-PAD-AD380-30 	A-PAD-AD425-30 	A-PAD-AD500-30 
Straight P.A.D. abutments Direct screw-retained Transgingival height 4.00 mm	A-PAD-AD330-40 	A-PAD-AD380-40 	A-PAD-AD425-40 	A-PAD-AD500-40 

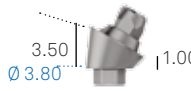
Please note: To transfer the abutments into the oral cavity each package contains a practical plastic carrier (code AVV-ABUT-DG, not available separately).

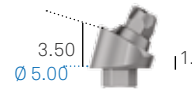
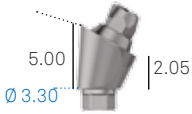
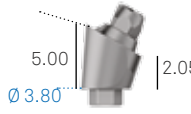
Recommended torque: 25-30 Ncm.

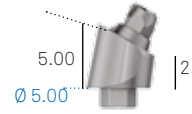
Angled P.A.D.

connection	Ø 3.30 mm	Ø 3.80 mm	Ø 4.25 mm	Ø 5.00 mm
P.A.D. abutments angled at 17° Transgingival height 3.00 mm Connecting screw included	A-PAD-AA330-173 	A-PAD-AA380-173 	A-PAD-AA425-173 	A-PAD-AA500-173 
P.A.D. abutments angled at 17° Transgingival height 5.00 mm Connecting screw included	A-PAD-AA330-175 	A-PAD-AA380-175 	A-PAD-AA425-175 	A-PAD-AA500-175 
P.A.D. abutments angled at 30° Transgingival height 3.00 mm Connecting screw included	A-PAD-AA330-303 	A-PAD-AA380-303 	A-PAD-AA425-303 	A-PAD-AA500-303 
P.A.D. abutments angled at 30° Transgingival height 5.00 mm Connecting screw included	A-PAD-AA330-305 	A-PAD-AA380-305 	A-PAD-AA425-305 	A-PAD-AA500-305 
Single pack Pack of 10 pieces Connecting screw for posts Supplied with the P.A.D., it can also be ordered separately as a spare	PAD-VM-180 PAD-VM-180-10 	Use PAD-VM-180	PAD-VM-180 PAD-VM-180-10 	Use PAD-VM-180

description	code
Carrier for transferring angled abutments into the oral cavity, sterilisable and reusable. Must be secured to the abutments with the screw	PAD-CAR 







Important warning

It is recommended always to use test screws for the laboratory phases and to keep the new screw supplied for the final fastening in the mouth.



Please note: To transfer the abutments into the oral cavity each package contains a practical plastic carrier (code AVV-ABUT-DG, not available separately).

Recommended torque for connecting screws: 20-25 Ncm.

All measurements are given in mm, unless indicated otherwise.

description	code
<p>Protection caps for P.A.D. abutments in Gr. 5 titanium, to be used if the abutments remain screwed to the implant during the lab phase. Connecting screw included (code PAD-VP-140), available also as a spare, to be tightened at 8-10 Ncm</p>	<p>PAD-CG</p> 
<p>Single pack Pack of 10 pieces</p> <p>Spare screw for P.A.D. abutment prosthetic components. Supplied with all the components for making the over-structure and also available as a spare</p>	<p>PAD-VP-140 PAD-VP-140-10</p> 
<p>Protection caps for P.A.D. abutments in PEEK, to be used if the abutments remain screwed to the implant during the lab phase. Recommended torque: 8-10 Ncm</p>	<p>PAD-CGP</p> 
<p>Rotating caps in POM for direct impression taking on P.A.D. abutments</p>	<p>PAD-CAP</p> 
<p>Non-rotating caps in POM for direct impression taking on P.A.D. abutments, with hexagon</p>	<p>PAD-CAP-EX</p> 
<p>Open tray transfer in Gr. 5 titanium for P.A.D. abutments, rotating. Long transfer screw included (code PAD-VTRAL-140), suitable for open impression tray and available also as a spare</p>	<p>PAD-TRA</p> 
<p>Open tray transfer in Gr. 5 titanium for P.A.D. abutments, with hexagon, non-rotating. Long transfer screw included (code PAD-VTRAL-140), suitable for open impression tray and available also as a spare</p>	<p>PAD-TRA-EX</p> 

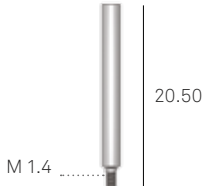
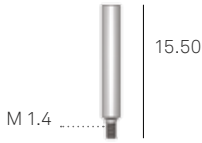
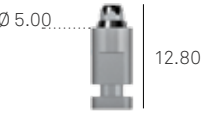

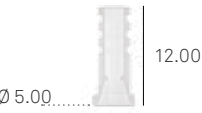

See the technical specifications of titanium, PEEK and POM, from page 92.

description	code
<p>Spare long screw for P.A.D. abutment transfer Supplied with the transfers, it can be ordered separately as a spare</p>	<p>PAD-VTRAL-140</p> 
<p>Spare screw for P.A.D. abutment transfer Supplied with the transfers, it can be ordered separately as a spare</p>	<p>PAD-VTRA-140</p> 
<p>Analog for P.A.D. abutment in Gr. 5 titanium</p>	<p>PAD-ANA</p> 
<p>Castable sleeves in PMMA for P.A.D. abutments, rotating. Connecting screw included. Attention: The recommended tightening torque for all the overstructures obtained by casting to the abutments is 20-25 Ncm. However, before casting, care must be taken in the laboratory to ensure that the castable sleeves are not fastened to the models with a torque exceeding 8-10 Ncm, because polymers are not as resistant as metal</p>	<p>PAD-CC</p> 
<p>Castable sleeves in PMMA for P.A.D. abutments, with hexagon, non-rotating. Connecting screw included. Attention: The recommended tightening torque for all the overstructures obtained by casting to the abutments is 20-25 Ncm. However, before casting, care must be taken in the laboratory to ensure that the castable sleeves are not fastened to the models with a torque exceeding 8-10 Ncm, because polymers are not as resistant as metal</p>	<p>PAD-CC-EX</p> 

For the technical specifications of the gold alloy "1" and of PMMA, refer to page 94 and 93 respectively.

Recommended torque for transfer screws: 8-10 Ncm.



All measurements are given in mm, unless indicated otherwise.

description	code
<p>PEEK sleeves for P.A.D. abutments, rotating. They are specifically for creating a temporary prosthesis or in cases when it is necessary to reline an old prosthesis to be used as a temporary one. Connecting screw included, to be tightened at 20-25 Ncm</p>	<p>PAD-CP</p> 
<p>PEEK sleeves for P.A.D. abutments, with hexagon, non-rotating. They are specifically for creating a temporary prosthesis or in cases when it is necessary to reline an old prosthesis for using as a temporary one. Connecting screw included, available also as a spare</p>	<p>PAD-CP-EX</p> 
<p>Castable posts in PMMA with a pre-made base in gold alloy, rotating, not repositionable, for overcasting on P.A.D. abutments. Connecting screw included, to be tightened at 20-25 Ncm. The head of the screw never rests on the PMMA, but always on the alloy base. The castable sleeve is also available as a spare (code A-CCUCR-330)</p>	<p>PAD-UC</p> 
<p>Castable posts in PMMA with a pre-made base in cobalt chrome, rotating, non-repositionable, for overcasting on P.A.D. abutments. Connecting screw included, to be tightened at 20-25 Ncm. The head of the screw never rests on the PMMA, but always on the alloy base. The castable sleeve is also available as a spare (code A-CCUCR-330)</p>	<p>PAD-UCRCO</p> 
<p>Single pack Pack of 10 pieces</p> <p>Spare screw for P.A.D. abutment prosthetic components. Supplied with all the components for making the over-structure and also available as a spare.</p>	<p>PAD-VP-140 PAD-VP-140-10</p> 

For the technical specifications of PEEK, PMMA, gold alloy and cobalt chrome, refer to page 93 and 94.

Recommended torque for connecting screws: 20-25 Ncm.

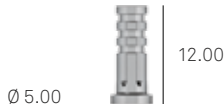
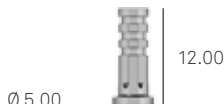
P.A.D. components for the relined and the cemented technique

description	code
<p>Sleeves in Gr. 5 titanium for P.A.D. abutments, rotating. They are specifically for an immediate and final restoration process or for relining an old prosthesis to be used as a temporary post. Connecting screw included (code PAD-VP-140), available also as a spare</p>	<p>PAD-CT</p> 
<p>Sleeves in Gr. 5 titanium for P.A.D. abutments, with hexagon, non-rotating. They are specifically for an immediate and final restoration process or for relining an old prosthesis to be used as a temporary post. Connecting screw included (code PAD-VP-140), available also as a spare</p>	<p>PAD-CT-EX</p> 
<p>Castable posts in PMMA for cementing on titanium sleeves Effective for restoration without residual tensions</p>	<p>PAD-CCEM</p> 
<p>Single pack Pack of 10 pieces</p> <p>Spare screw for P.A.D. abutment prosthetic components Supplied with all the components for making the over-structure and also available as a spare.</p>	<p>PAD-VP-140 PAD-VP-140-10</p> 

For the technical specifications of titanium and PMMA, refer to page 92 and 93 respectively.

Recommended torque for connecting screws: 20-25 Ncm.





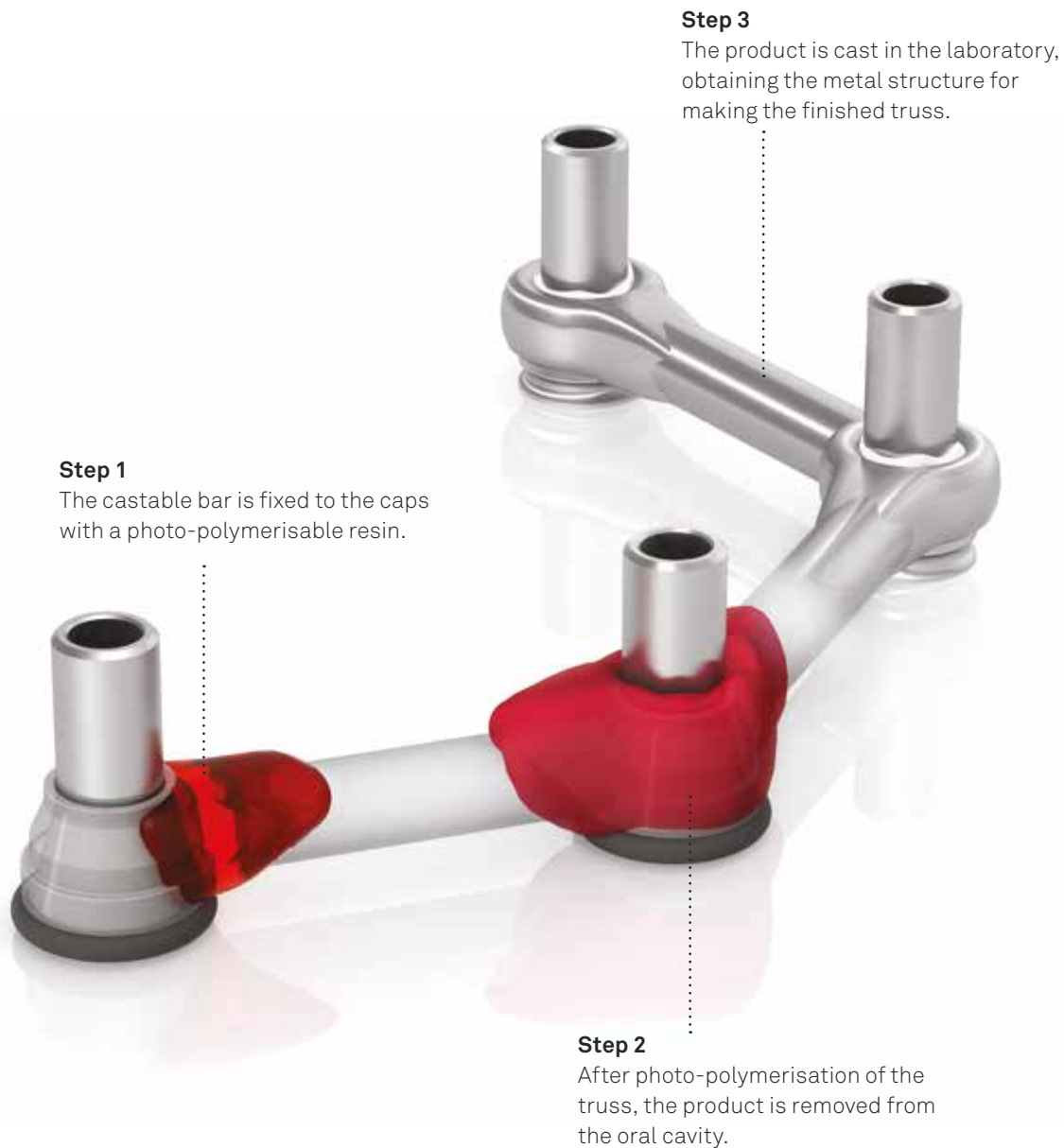

All measurements are given in mm, unless indicated otherwise.

P.A.D. prosthesis for “D.P.F.” Technique (Direct Prosthetic Framework)

P.A.D. abutments have proven to be a valid support for creating various simplified prosthetic protocols, including the creation of temporary posts for full-arch implant rehabilitations with immediate loading with a very simple and safe procedure. The D.P.F. components have been specially developed for creating a castable resin structure directly in the oral cavity that is absolutely passive, not restricted by connection geometries and with the additional advantage of being made without errors due to the taking of the impression and the development of the model. The intra-oral cementing of the metal truss obtained subsequently by casting allows the times for inserting the reinforced temporary post to be reduced to 8 hours after the end of surgery, while still maintaining the important properties of resistance and passivity during the first phase of implant loading.

The temporary post created in this way can also be used as a positioning stent for making the final prosthesis.



description	code
Complete pack of all the prosthetic components for the "D.P.F." technique on a single P.A.D. abutment. The pack includes the titanium sleeve (PAD-CT-LV), the castable centring device (PAD-CC-LV), the anti-escape plug (PAD-TR-LV), the protective o-ring (PAD-ORING-LV) and the connecting screw (PAD-VP-140) to be tightened at 20-25 Ncm, available also as a spare.	PAD-LV 
Spare titanium sleeve for the "D.P.F." technique. The pack does not include the connecting screw.	PAD-CT-LV 
Spare castable centring device for the "D.P.F." technique	PAD-CC-LV 
Spare anti-escape plug for the "D.P.F." technique	PAD-TR-LV 
Spare O-ring for the "D.P.F." technique.	PAD-ORING-LV 
Single pack Pack of 10 pieces Spare screw for P.A.D. abutment prosthetic components. Supplied with all the components for making the over-structure and also available as a spare.	PAD-VP-140 PAD-VP-140-10 
Castable bar, length 5.00 cm, Ø 2.20 mm	BARC 

See PMMA technical characteristics on page 93.

Recommended torque for connecting screws: 20-25 Ncm.

All measurements are given in mm, unless indicated otherwise.

Prosthesis on PLAIN abutments



















PLAIN abutments exploit the completely flat geometry of the upper part which, by means of a very small guide, is joined to normal castable sleeves. The usefulness of these abutments is therefore that they maximise centring and repositioning operations of structures screwed onto several implants.



The **healing abutments** allow optimum tissue conditioning thanks to an emergence profile that is very flared at the crown. The healing caps do not have a passing screw but are screwed directly onto the abutment.

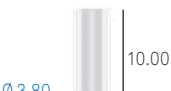
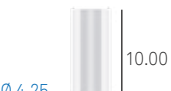

The **PLAIN system** also includes transfers and analogs in a single size, which allow the impression to be taken directly on the abutment. The open tray transfer has a special long screw supplied with it.

The **guide** for lodging the castable sleeves is only 0.20 mm, the minimum indispensable for centring the prosthesis.

connection	Ø 3.30 mm	Ø 3.80 mm	Ø 4.25 mm	Ø 5.00 mm
PLAIN abutment Direct screw-retained, Transgingival height 2.00 mm	A-PLAIN-ABU330-2 	A-PLAIN-ABU380-2 	A-PLAIN-ABU425-2 	A-PLAIN-ABU500-2 
PLAIN abutment Direct screw-retained, Transgingival height 3.00 mm	A-PLAIN-ABU330-3 	A-PLAIN-ABU380-3 	A-PLAIN-ABU425-3 	A-PLAIN-ABU500-3 
PLAIN abutment Direct screw-retained, Transgingival height 4.00 mm	A-PLAIN-ABU330-4 	A-PLAIN-ABU380-4 	A-PLAIN-ABU425-4 	A-PLAIN-ABU500-4 
Healing abutment for PLAIN abutment	A-PLAIN-CG330 	A-PLAIN-CG380 	A-PLAIN-CG425 	A-PLAIN-CG500 
Castable sleeves for PLAIN abutments Connecting screw included	A-PLAIN-CC330 	A-PLAIN-CC380 	A-PLAIN-CC425 	A-PLAIN-CC500 
Single pack Pack of 10 pieces Connecting screws for castable sleeve for PLAIN abutments Supplied with the sleeves, it can also be ordered separately as a spare	A-PLAIN-VP200 A-PLAIN-VP200-10 	Use A-PLAIN-VP200	Use A-PLAIN-VP200	Use A-PLAIN-VP200

description	code
Analog for PLAIN abutment	PAD-CT 
Transfer for PLAIN abutment. Connecting screw included	PAD-CT-EX Ø 4.30 
Spare screw for PLAIN transfer. Supplied with the transfers for PLAIN abutments, it can also be ordered separately as a spare	PAD-CCEM 

Important warning

It is recommended always to use test screws for the laboratory phases and to keep the new screw supplied for the final fastening in the mouth.

Note: for transferring PLAIN abutments into the oral cavity, screwing and tightening them, use the standard screwdrivers (code HSM-20-EX and HSML-20-EX for use with the torque-control ratchet) contained in the Premium kit.

Recommended torque for connecting screws: 20-25 Ncm.

Recommended torque for Plain abutments: 25-30 Ncm.





All measurements are given in mm, unless indicated otherwise.

T-Connect

T-Connect supports can be used for making individualised posts in zirconium with open CAD CAM systems without sacrificing micrometric precision in the join between the platforms that can be obtained with traditional components.

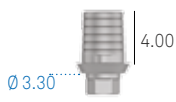
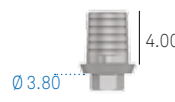

T-Connect: allow a perfect join to be obtained between prosthesis and implant with zirconium structures milled and sintered in the laboratory.

connection	Ø 3.30 mm	Ø 3.80 mm	Ø 4.25 mm	Ø 5.00 mm
T-Connect supports in Gr. 5 titanium for custom-made posts in zirconium Repositionable Connecting screw included	A-BASTZR-S-330 	A-BASTZR-S-380 	A-BASTZR-S-425 	A-BASTZR-S-500 
Single pack Pack of 10 pieces Spare screw for T-Connect supports Supplied with the T-Connect supports, it can also be ordered separately as a spare	VM2-180 VM2-180-10 	Use VM2-180	VM2-180 VM2-180-10 	Use VM2-180

Important warning

It is recommended always to use test screws for the laboratory phases and to keep the new screw supplied for the final fastening in the mouth.

Recommended torque for connecting screws: 20-25 Ncm.

All measurements are given in mm, unless indicated otherwise.

Try-in kit

The kit is composed of a complete series of Try-in in anodised aluminium, in different angles, profiles and transgingival emergence heights, useful for checking the spaces occupied by the prosthetic posts in the model design phase.

The practical Plexiglass box is marked, under each seat, with the corresponding schematic drawing of the piece, with details of the dimensions and two codes; at the top, the code of the respective post to be ordered for the final prosthesis and at bottom right with the code of the Try-in, for re-ordering if required.

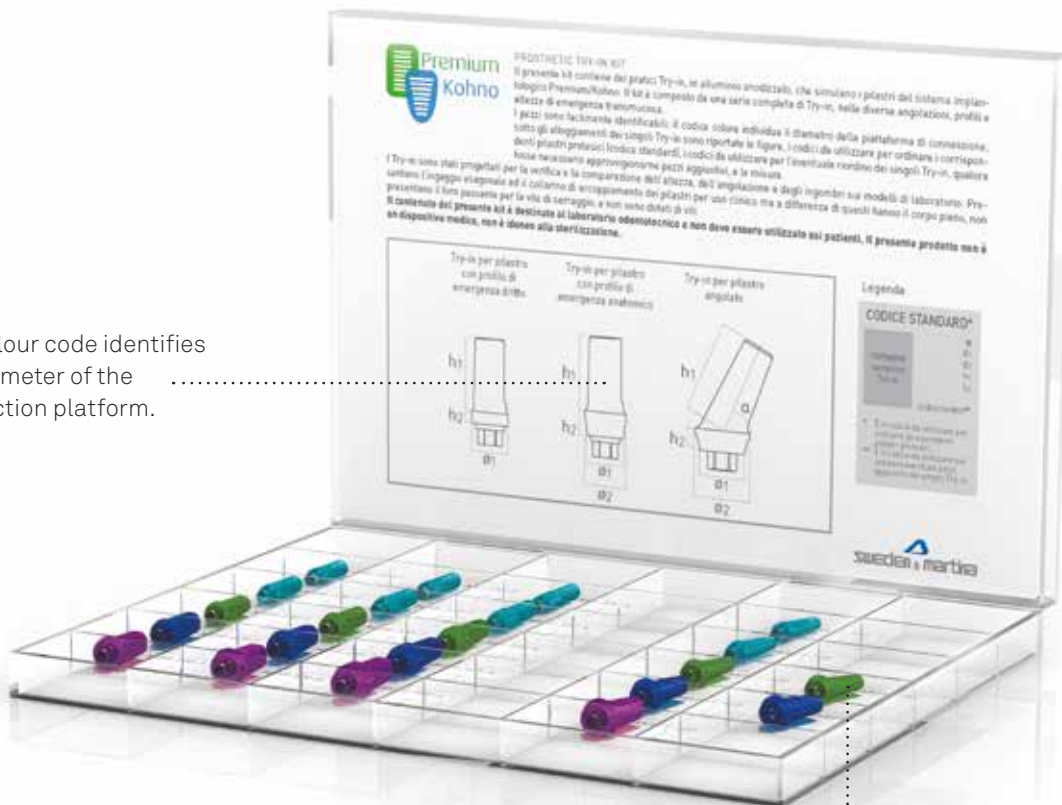

The colour code identifies the diameter of the connection platform.

The Try-ins are without connecting screws because the hexagonal connections have practical retentive tabs. The friction also allows the Try-in to be used in an articulator on the model of the upper arch.



description	code	
Complete Try-in kit for Premium implants	A-TRY-IN-KIT-INT	
Empty tray in Plexiglass	A-T-TRAY-INT	

Locator abutment

Locator abutments* are a patented and versatile prosthetic solution for attaching overdentures to dental implants easily and safely. The Locator system allows easily correcting misalignment of divergent implants by up to 40° (20° for each implant) in limited occlusal spaces and, given the limited amount of space occupied, is perfect for patients with a removable prosthesis. The abutments are made of Gr. 5 titanium and are available in different transgingival heights. The Locators must be tightened at 25-30 Ncm, using the special driver provided in the Screw Kit and also available separately on request (code 8926-SW, short, and code 8927-SW, long). See page 88 for the list of accessories available.



The self-guiding design of the head of the Locator abutment allows easy insertion of the prosthesis. The self-alignment of the prosthesis reduces deterioration of the pieces and increases the life of the device.

The Locator system has a practical steel or titanium cap where the retainer lodges inside the prosthesis. When the retainer loses retentiveness, it can be easily replaced because there is no need to extract it from the resin by removing material from the prosthesis, but it can be simply extracted from the metal cap, which remains attached to the prosthesis.

* *Locator Abutments are medical devices manufactured and patented by Zest Anchors, Inc., 2061 Wineridge Place, Escondido, CA 92029, USA. Locator is a registered trademark of Zest Anchors, Inc. The European Agent for the purposes of MDD 93/42/EEC is Ventura Implant and Attachment Systems, 69 The Avenue, Ealing, London W13 8JR, England.*









connection	Ø 3.30 mm	Ø 3.80 mm	Ø 4.25 mm	Ø 5.00 mm
Locator Abutment Straight emergence profile Transgingival height 1.00 mm	1670 	1675 	1681 	2724 
Locator Abutment Straight emergence profile Transgingival height 2.00 mm	1671 	1676 	1682 	2725 
Locator Abutment Straight emergence profile Transgingival height 3.00 mm	1672 	1677 	1683 	2726 
Locator Abutment Straight emergence profile Transgingival height 4.00 mm	-	1678 	1684 	2727 
Locator Abutment Straight emergence profile Transgingival height 5.00 mm	-	1679 	1685 	-
Locator Abutment Straight emergence profile Transgingival height 6.00 mm	-	1680 	1686 	-

Overdentures anchored with ball attachments

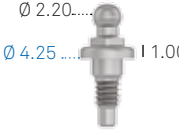
There is a small hexagon at the base of the ball for attaching the driver (N.B.: the driver is not included in the surgical kit, it is in the Screw kit of prosthetic drivers (see page 19) and may be ordered separately, with code BASCC-EX). This driver is compatible with the system's.

See page 90 for the list of the available matrices and respective accessories.

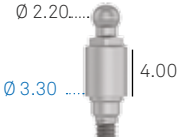
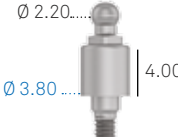
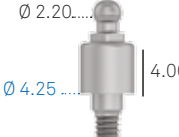

connection	Ø 3.30 mm	Ø 3.80 mm	Ø 4.25 mm	Ø 5.00 mm
Ball attachments Straight emergence profile Transgingival height 1.00 mm	A-AS-330-1 	A-AS-380-1 	A-AS-425-1 	-
Ball attachments Straight emergence profile Transgingival height 2.00 mm	A-AS-330-2 	A-AS-380-2 	A-AS-425-2 	A-AS-500-2 
Ball attachments Straight emergence profile Transgingival height 4.00 mm	A-AS-330-4 	A-AS-380-4 	A-AS-425-4 	-
Analog of the ball attachment	ANAS 	Use ANAS	Use ANAS	Use ANAS

description	code
Steel driver for ball attachments, with connector for torque-control ratchet or digital connector. Not included in the surgical kit, included in the Screw Kit and can be ordered separately	BASCC-EX 

Recommended torque: 25-30 Ncm.

All measurements are given in mm, unless indicated otherwise.

SFI-Bar*

The total removable prosthesis supported by implants is acquiring more and more importance in prosthetic restorations. To enable patients to enjoy a substantially better quality of life on a long-term basis thanks to optimum retention, the principle of treatment with bars on implants has been radically reviewed, creating the SFI-Bar. The result is an exclusive solution that offers numerous clinical and economic advantages for patients, dentists and dental technicians in comparison with conventional bars.

The abutment driver for the SFI-Bar can be ordered separately, with code 07000046-SW. This driver is compatible with the system's dynamometric ratchet.

See page 86 for the list of available accessories.

Chair-side and lab-side processing: Thanks to the extremely reduced production times, the SFI-Bar can be processed either chair-side or in the laboratory. In both cases the exclusive bar system with prefabricated elements is convincing for its almost universal possibilities of use, with costs reduced to a minimum in comparison with the traditional bar solution.



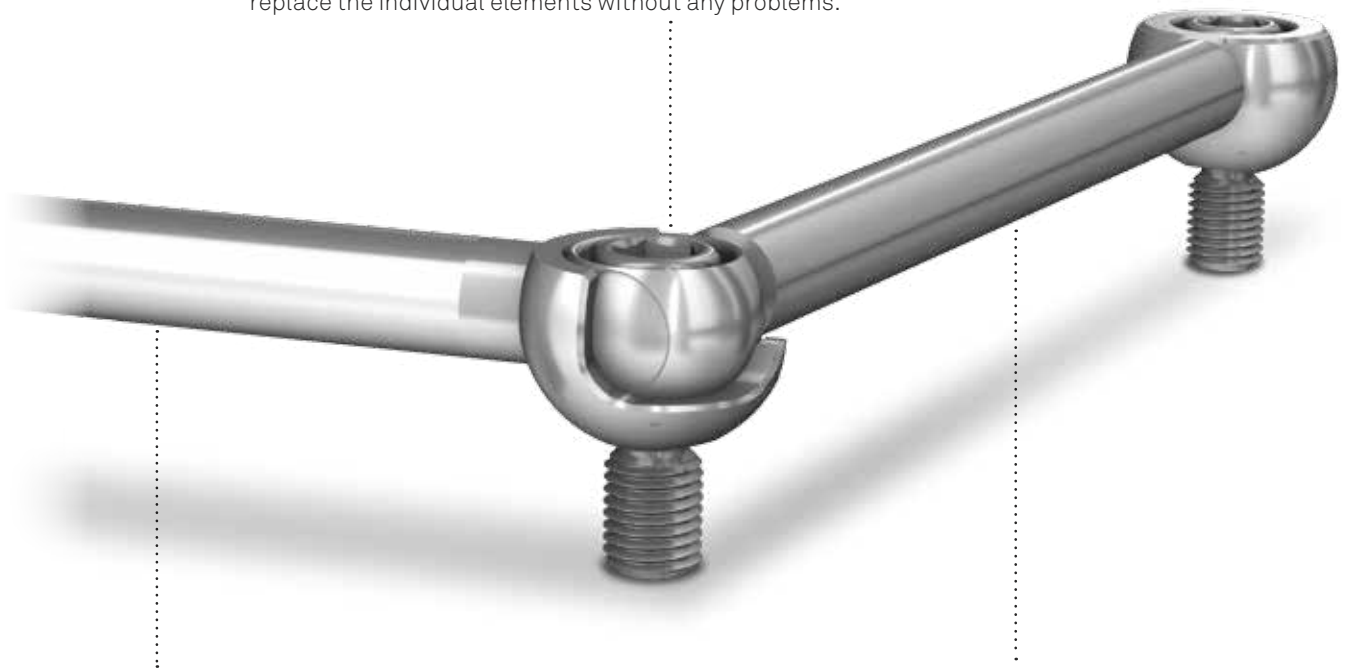



The bar prostheses made with the SFI-Bar can be supported by 3, 4, 5 or 6 implants, they take up less space in the mouth and present characteristics of biocompatibility. In case of repair it is possible to replace the individual elements without any problems.

















Immediate loading: SFI-Bar offers the ideal basis for carrying out the immediate loading treatment, which exploits the complete absence of stress that can be obtained with this prosthetic protocol. This improves acceptance of the prosthesis by the patient and creates the conditions for optimum osseointegration.

Passive Fit: The stress-free position of a bar treatment is a fundamental requirement for the long-term clinical success of a prosthesis supported by implants. SFI-Bar offers the ideal basis for carrying out the immediate loading treatment, which exploits the complete absence of stress that can be obtained with this prosthetic protocol.

* The components for SFI-Bar prostheses are medical devices manufactured by Cendres+Métaux, Rue de Boujean 122 CH-2501 Biel/Bienne.











connection	Ø 3.30 mm	Ø 3.80 mm	Ø 4.25 mm	Ø 5.00 mm
Abutments for SFI-Bar Transgingival height 3.00 mm	-	05001001 	05001007 	-
Abutments for SFI-Bar Transgingival height 4.00 mm	-	05001002 	05001008 	-
Abutments for SFI-Bar Transgingival height 5.00 mm	-	05001003 	05001009 	-











OVERDENTURE

description	code	
2-implant kit, including: 2 large ball joint, 2 connecting screws, 1 tube bar in Gr. 5 titanium	05000337	
4-Implant kit, including: 2 large ball joint, 2 small ball joint, 2 Half shell balls, 4 connecting screws, 3 tube bars in Gr. 5 titanium	05000338	
Add-on kit, including: 1 small ball joint, 1 half shell ball, 1 connecting screw, 1 tube bar in Gr. 5 titanium	05000668	
Tube bar, length 20 mm, in Gr. 5 titanium	05000382	
Large ball joint in Gr. 5 titanium	05000383	
Small ball joint in Gr. 5 titanium	05000384	
Half shell ball in Gr. 5 titanium	05000385	
Fixation screw in Gr. 5 titanium	05000386	
Pack of 1 piece Female part asymmetrical, length 30.00 mm in gold alloy.	05000344	
Female part complete, length 47.50 mm, in Gr. 5 titanium and plastic material. 1 bar with 12 segments, 6 yellow sheaths and 6 red sheaths	05000358	
Female part housing, length 47.50 mm in Gr. 5 titanium. 1 bar with 12 segments	05000387	
Pack of 6 pieces Yellow retention insert - smooth friction, in POM copolymer.	05000388	
Pack of 6 pieces Red retention insert - normal friction, in POM copolymer.	05000389	
Pack of 6 pieces Green retention insert - strong friction, in POM copolymer.	05000390	

description	code
Instrument set	07000108 
Spacer Brass, ensures vertical resilience. Mount between female part and bar during polymerization.	052082
Transfer jig length 26.00 mm	07000107
Tube bar gauge	07000106
Gauge aid	07000100
Screwdriver	07000114
Hex key	07000115
Thomas spanner key	070221
Insert positioner	07000036
Activator set	070198
Desactivator macro	070201
Tweezers	070347
Implant planner	07000111
Premium disk No. 1	08000101

Accessories for overdentures on Locator abutments

description	code
Kit containing 2 Gr. 5 titanium caps, 2 spacer rings in silicon rubber, 2 black processing polyethylene retainers (LDPE) with low retention capacity and 2 nylon retainers for each of the 4 different retention capacities	8519-2 
Kit containing 2 Gr. 5 titanium caps, 2 spacer rings in silicon rubber, 2 black processing polyethylene retainers (LDPE) with low retention capacity and 2 nylon retainers for each of the 4 different retention capacities, designed for severe disparallelism	8540-2 
Kit containing 2 steel caps, 2 spacer rings in silicon rubber, 2 black processing polyethylene retainers (LDPE) with low retention capacity and 2 nylon retainers for each of the 4 different retention capacities	8550-2 
Pack of 20 spacer rings in silicon rubber	8514
Pack of 4 black processing polyethylene retainers (LDPE) with low retention capacity	8515 
Pack of 4 transparent nylon retainers, retention 5 lb	8524 
Pack of 4 pink nylon retainers, retention 3 lb	8527 
Pack of 4 blue nylon retainers, retention 1.5 lb	8529 
Pack of 4 green nylon retainers, retention 4 lb	8547 
Pack of 4 red nylon retainers, retention 1 lb	8548 
Pack of 4 orange nylon retainers, retention 2 lb	8915 



description	code
Pack of 4 aluminium analogs for Locator abutments, one size for all platforms	8530 
Pack of 4 aluminium transfers for Locator abutments, one size for all platforms. 4 black polyethylene retainers (LDPE) with low retention included (code 8515), available also as a spare	8505 
Pack of 4 black nylon parallelism pins (LDPE) for Locator abutments	8517 
Steel plate AISI 316L for measuring angles	9530 
Locator Core Tool. Steel instrument composed of a handle, driver (8390) for inserting Locator abutments, tip (8397) for inserting the retainers in the caps and the retention jacket (8394) for the driver (8390) for transferring the Locator abutments into the oral cavity	8393 
Replacement of the steel tip for inserting the retainers into the caps	8397 
Replacement of the steel driver for abutment screwing/unscrewing	8390 
Replacement of the retention jacket for the driver (8390) for transferring the Locator abutments into the oral cavity	8394 
Short driver in Gr. 5 titanium for torquing the Locator abutments. The driver is compatible with the torque-control ratchet	8926-SW 
Long driver in Gr. 5 titanium for torquing the Locator abutments. The driver is compatible with the torque-control ratchet	8927-SW 

Locator abutments are manufactured and patented by Zest Anchors, Inc., 2061 Wineridge Place, Escondido, CA 92029, USA. Locator is a registered trademark of Zest Anchors, Inc.





All measurements are given in mm, unless indicated otherwise.

Accessories for overdentures on ball attachments

Polyamide caps for ball attachments

description	code
Polyamide cap for ball attachments Ø 2.20 mm	CAP-TFL-1 
Steel container for polyamide cap with outer Ø 4.80 mm. The total height is 3.20 mm	CONT-CAP-TFL-1 





Titanium caps for ball attachments

description	code
Gr. 5 titanium cap complete with cap in two parts, titanium retention spring, and plastic mounting ring for ball attachments Ø 2.20 mm. The total height is 3.20 mm	CAP-TIT-1 
Spare plastic ring for titanium cap height 2.20 mm	AN-CAP-TIT-1 
Spare retention spring for titanium caps, average hardness, steel, Ø 3.20 mm	MOL1-CAP-TIT-1 
Spare retention spring for titanium cap, soft, for progressive adaptation of the prosthesis, steel, Ø 3.20 mm	MOL2-CAP-TIT-1 
Instrument for assembly and maintaining the titanium cap for CAP-TIT-1 ball attachments	AVV-CAP-TIT-1 

Caps in gold alloy for ball attachments





description	code
Cap in gold alloy, complete with plastic positioning ring for ball attachments Ø 2.20 mm. The total height is 3.10 mm, and the outside diameter is 3.50 mm	CAP-1 

O-ring retention devices for ball attachments

description	code	
Pack of 6 pieces Metal container in the shape of a ring for rubber O-rings. For ball attachments \varnothing 2.20 mm. The total height is 1.50 mm, and the outside diameter is 4.50 mm.	99-440044*	
Pack of 12 pieces Red ring in silicon for laboratory use, outside \varnothing 4.50 mm, height 1.50 mm.	99-443034*	
Pack of 12 pieces White ring in natural rubber, soft, outside \varnothing 4.50 mm, height 1.50 mm.	99-443035*	
Pack of 12 pieces Black ring in natural rubber, hard, outside \varnothing 4.50 mm, height 1.50 mm.	99-443036*	

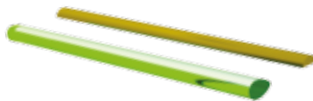
* The retention O-rings for ball attachments are manufactured by Implant Direct Sybron International, 3050 East Hillcrest Drive, Thousand Oaks, CA 91362 U.S.A.
The European Agent for the purposes of MDD 93/42/EEC is Kerr Italia S.r.l., via Passanti 332, 84018 Scafati (SA) Italy.

Overdentures on bars

description	code	
Castable bar, length 5.00 cm, height 3.00 mm, thickness 1.90 mm Ovoid-shaped profile with spacer	BARC-CAV-TIT	
Divisible bar attachment in titanium for oval bars with \varnothing 1.90 mm and height 3.00 mm	CAV-TIT	
Castable bar, length 5.00 cm, \varnothing 1.90 mm	BARC	
Bar attachment in gold alloy, for round bars with \varnothing 1.90 mm	CAV-375	

All measurements are given in mm, unless indicated otherwise.

MATERIAL COMPONENTS

Gr. 4 TITANIUM (cold worked)*	Maximum allowed values (%)	Tolerance
Chemical composition:		
Nitrogen	0.05	+/- 0.02
Carbon	0.08	+/- 0.02
Hydrogen	0.015	+/- 0.002
Iron	0.50	+/- 0.01 (%<0.25) +/- 0.15 (%>0.25)
Oxygen	0.40	+/- 0.02 (%<0.20) +/- 0.03 (%>0.20)
Titanium	remainder	-
Mechanical properties*		
Tensile stress:	680 MPa (N/mm ²)	
Yield strength:	520 MPa (N/mm ²)	
Ultimate elongation:	15 %	
Section reduction:	25 %	

* This technical information complies with the express specifications of the regulations in force for the use of Gr. 4 titanium in implantology:

- ASTM F67-06: Standard Specification for unalloyed titanium, for surgical implant applications.
- ISO 5832-2:1999: Implant for surgery – Metallic materials – Part 2: Unalloyed titanium.

N.B.: the use of bars obtained from cold processing, for the production of Sweden & Martina Spa implants, allows the exploitation of the mechanical characteristics of tensile strength and yield strength about 15% higher than those that can be obtained with a hot process (respectively 550 MPa and 483 MPa).

GRADE 5 TITANIUM**	Maximum allowed values (%)	Tolerance
Chemical composition:		
Nitrogen	0.05	+/- 0.02
Carbon	0.08	+/- 0.02
Hydrogen	0.012	+/- 0.002
Iron	0.25	+/- 0.10
Oxygen	0.13	+/- 0.02
Aluminium	0.50÷6.50	+/- 0.40
Vanadium	3.50÷4.50	+/- 0.15
Titanium	remainder	-
Mechanical properties*		
	Minimum allowed values	
Tensile stress (for bar diameters up to 44.45 mm):	860 MPa (N/mm ²)	
Yield strength (0.2%):	795 MPa (N/mm ²)	
Ultimate elongation:	10 %	
Section reduction:	25 %	

** This technical information complies with the express specifications of the regulations in force for the use of Gr. 5 titanium in implantology:

- ASTM F136-11: Standard Specification for wrought Titanium-6Aluminum-4Vanadium ELI (Extra low Interstitial) Alloy for surgical implant applications;
- ISO 5832-3:1996: Implants for surgery – Metallic materials – Part 3: Wrought titanium 6-aluminium 4-vanadium alloy.

PMMA	
Chemical designation:	Polymethylmethacrylate
Colour:	Transparent
Physical and mechanical properties	
Density (DIN 53479)	1.18 g/cm ³
Yield strength (DIN 53454)	110 N/mm ²
Elongation at yield (DIN 53455)	5.5 %
Modulus of elasticity (DIN 53457)	115 N/mm ²
Tangential elastic modulus at 10 Hz (DIN 53445)	3300 N/mm ²
BRINELL hardness ball falling h961/30 (DIN 53456)	1700 N/mm ²
BRINELL hardness if the ball falls (DIN 53456)	200 N/mm ²
Thermal properties	
Coefficient of linear extension for 0...50C (DIN VDE 0304/01)	70·10 ⁻⁶ · 1/°C
Thermal conductivity (DIN 52612)	0.19 W/m °C
Oven temperature	≈ 160 °C
Regaining temperature	>80 °C
Maximum service temperature long term	78 °C
VICAT temperature, proceeding B (DIN 53460)	115 °C
ISO 75 flecion resistance 1.80N/mm ² (DIN 53461)	105 °C
Heat resistance according martens (DIN 53458)	95 °C
Chemical properties	
Water absorption in weight increase after 1 day immersion (DIN 53495)	0.3 %

POM	
Chemical designation	Polyoxymethylene (copolymer)
Colour	Natural opaque
Physical and mechanical properties	
Density (DIN 53479):	1.41 g/cm ³
Tensile strength (DIN EN ISO 527-2)	67 Mpa
Tensile strenght at yield (DIN EN ISO 527-2)	67 Mpa
Elongation at yield (DIN EN ISO 527-2):	9%
Elongation at break (DIN EN ISO 527-2):	32 %
Modulus of elasticity (flexural test) (DIN EN ISO 178):	2800 Mpa
Modulus of elasticity (tensile test) (DIN EN ISO 527-2):	2800 MPa
Ball indentation hardness (ISO 2039-1):	165 MPa
Impact strength (Charpy) (DIN EN ISO 179-1eU):	Not broken
Compression modulus (EN ISO 604):	2300 Mpa
Thermal properties	
Melting temperature (DIN 53765):	166 °C
Glass transition temperature (DIN 53765):	-60 °C
Service temperature short term:	140 °C
Service temperature long term:	100 °C
Specific heat (ISO 22007-4):	1.4 J/(gK)
Thermal conductivity (ISO 22007-4):	0.39 W/ (mK)
Thermal expansion (CLTE) 23-60°C (DIN EN ISO 11359-1;2):	13·10 ⁻⁵ /K
Thermal expansion (CLTE) 23-100°C (DIN EN ISO 11359-1;2):	14·10 ⁻⁵ /K
Chemical properties	
Water absorption 24h / 96h (23°C) (DIN EN ISO 62)	0.05/0.1%

MATERIAL COMPONENTS

PEEK *(tested on the same quantity of material)	Radiopaque	Classic
Chemical designation	Polyetheretherketone	Polyetheretherketone
Colour	Cream white opaque	Cream white opaque
Physical and mechanical properties		
Density:	1.65 g/cm ³	1.4 g/cm ³
Modulus of elasticity (tensile test) (DIN EN ISO 527-2):	5200 MPa	4100 MPa
Tensile strength (DIN EN ISO 527-2):	77 MPa	97 MPa
Tensile strength at yield (DIN EN ISO 527-2):	77 MPa	97 MPa
Elongation at yield (DIN EN ISO 527-2):	2%	5%
Elongation at break (DIN EN ISO 527-2):	2%	13%
Flexural strength (DIN EN ISO 178):	178 MPa	174 MPa
Modulus of elasticity (flexural test) (DIN EN ISO 178):	5000 MPa	4000 MPa
Compression modulus (EN ISO 604):	4000 MPa	3500 MPa
Thermal properties		
Glass transition temperature (DIN 53765):	-	150 °C
Service temperature short term:	300 °C	300 °C
Chemical properties		
Water absorption 24h / 96h (23°C) (DIN EN ISO 62):	-	0.02/0.03 %

GOLD ALLOY	Gold alloy 1	Gold alloy 2	Gold alloy 3
Chemical designation	Gold alloy 1	Gold alloy 2	Gold alloy 3
Colour	White	Yellow	Yellow
Composition			
Au	60 %	> 68.60 %	70 %
Pt	24 %	2.45 %	8.5 %
Pd	15 %	3.95 %	-
Ir	1 %	0.05 %	0.10 %
Ag	-	11.85 %	13.40 %
Cu	-	10.60 %	7.50 %
Zn	-	2.50 %	0.50 %
Au + Pt Group Metals	-	75.35 %	-
Ru	-	-	-
Physical and mechanical properties			
Density:	18.1 g/cm ³	15.0 g/cm ³	15.7 g/cm ³
Melting range:	1400 ÷ 1460 °C	880 ÷ 940 °C	895 ÷ 1010 °C
Modulus of elasticity (tensile test):	115 GPa	97 GPa	100 GPa
Vickers Hardness HV1 (Gold alloy 1) HV5 (Gold alloy 2, Gold alloy 3)	160 (annealed) 250 (hardened) 220 (after deformation) 240 (after casting)	> 240	170 (annealed) 295 (hardened) 280 (selfhardening)
Proof stress Rp0.2	400 MPa (annealed) 700 (after deformation) 800 (after casting)	> 710 MPa (cold worked) 410 Mpa (soft) 680 Mpa (hardened)	380 MPa (annealed) 730 (after deformation)
Yield strenght Rm	600 Mpa (annealed) 850 (hardened) 850 (after deformation)	>790 MPa (cold worked) 535 MPa (soft) 780 MPa (hardened)	-
Elongation in %	20 % (annealed) 15 (hardened) 1 (after deformation)	> 4 % (cold worked) 35% (soft) 12% (hardened)	-

COBALT CHROME ALLOY	Maximum allowed values (%)
Chemical composition:	
C	0.10
Mn	1.00
Cr	26.00 ÷ 30.00
Ni	1.00
Mo	5.00 ÷ 7.00
N	0.25
Fe	0.75
Co	balanced
Physical and mechanical properties:	
Density	8.27 g/cm ³
Modulus of elasticity – Tensile test:	241 GPa
Yield strength (0.2%):	585 MPa
Tensile stress:	1035 MPa
Ultimate elongation:	25 %
Section reduction:	23 %
Hardness:	30 HRc
Thermal properties	
Melting range:	1400 ÷ 1450 °C
Coefficient of thermal expansion:	
at 500 °C:	14.15
at 600 °C:	14.47
Thermal conductivity:	
at 600 °C:	25.76 W/mK

- Segura Andrés G., Martínez Lage J. F., Ferreiroa A., Faus Lòpez J., Agustín Panadero R.; Rehabilitación protésica en un maxilar atrófico a consecuencia de un trauma facial; *Gaceta Dental*, 2013; 244:112-118
- Canullo L., Micarelli C., Clementini M.; Hard tissue response to argon plasma cleaning treatment on titanium abutments: 2-year follow-up RCT; *European Journal of Oral Implantology*, 6 (Suppl. Spring), 2013: S21-S22
- Rossi F., Lang N. P., De Santis E., Morelli F., Favero G., Botticelli D.; Bone-healing pattern at the surface of titanium implants: an experimental study in the dog; *Clinical Oral Implant Research*, Early View, First Published online on 2013, January 4th; DOI: 10.1902/jop.2010.100428
- Clementini M., Canullo L., Micarelli C.; Fibroblast growth on titanium disks treated by argon plasma: an in vitro triple-blinded study; *European Journal of Oral Implantology*, 6 (Suppl. Spring), 2013: S29-S30
- Canullo L., Micarelli C., Iannello G.; Microscopical and chemical surface characterization of the gingival portion and connection of an internal hexagon abutment before and after different technical stages of preparation; *Clinical Oral Implant Research*, 2013, 24: 606-611; DOI: 10.1111/j.1600-0501.2012.02499.x
- Canullo L., Heinemann F., Gedrange T., Biffar R., Kunert-Keil C.; Histological evaluation at different times after augmentation of extraction sites grafted with a magnesium-enriched hydroxyapatite: double-blinded randomized controlled trial; *Clinical Oral Implant Research*, Early View, First Published online on 2013, January 4th; DOI: 10.1111/clr.12035
- Canullo L., Micarelli C., Carinci F.; Cleaning procedures on customized abutments: microscopical, microbiological and chemical analysis; *Clinical Oral Implant Research*, 2012; 23 Suppl 7: 55-56; DOI: 10.1111/clr.12019, 2012, 23(s7_128)
- Canullo L., Micarelli C., Lembo-Fazio L., Iannello G., Clementini M.; Microscopical and microbiologic characterization of customized titanium abutments after different cleaning procedures; *Clinical Oral Implant Research*, Early View, First Published online on 2012, December 5th, DOI: 10.1111/clr.12089
- Wennstrom J. L., Derks I.; Is there a need for keratinized mucosa around implants to maintain health and tissue stability?; *Clinical Oral Implant Research*, 2012; 23 Suppl 6: 136-146; DOI: 10.1111/j.1600-0501.2012.0254.x
- Sisti A., Canullo L., Mottola M. P., Covani U., Barone A., Botticelli D.; Clinical evaluation of a ridge augmentation procedure for the severely resorbed alveolar socket: multicenter randomized controlled trial, preliminary results; *Clinical Oral Implant Research*, 2012; 23: 526-535; DOI: 10.1111/j.1600-0501.2011.02386.x
- Sailer I., Muhlemann S., Zwahlen M., Hämmerle C. H. F., Schneider D.; Cemented and screw-retained implant reconstructions: a systematic review of the survival and complication rates; *Clinical Oral Implant Research*, 2012; 23 Suppl 6: 163-201; DOI: 10.1111/j.1600-0501.2012.02538.x
- Barone A., Orlando B., Cingano L., Marconcini S., Derchi G., Covani U.; A randomized clinical trial to evaluate and compare implants placed in augmented vs. non-augmented extraction sockets A 3-year evaluation; *Journal of Periodontology*, 2012; 83: 836-846; DOI: 10.1902/jop.2011.110205
- Sisti A., Canullo L., Mottola M. P., Iannello G.; Crestal minimally invasive sinus lift on severely resorbed maxillary crest: prospective study; *Biomedizinische Technik/Biomedical Engineering*, 2012, 57, ISSN (Online) 1862-278X, ISSN (Print) 0013-5585; DOI: 10.1515/bmt-2011-0038
- Crespi C., Capparé P., Gherlone E.; Sinus floor elevation by osteotome: hand mallet versus electric mallet. A prospective clinical study; *The International Journal of Oral & Maxillofacial Implants*, 2012; 27: 1144-50; DOI: 10.1111/j.1708-8208.2012.00485.x
- Al-Nsour M., Chan H. L., Wang H. L.; Effect of the platform-switching technique on preservation of peri implant marginal bone: a systematic review; *International Journal of Oral and Maxillofacial Implants*, 2012; 27: 138-145
- Annibaldi S., Bignozzi I., Cristalli M. P., Graziani F., La Monaca G., Polimeni A.; Peri-implant marginal bone level: a systematic review and meta-analysis of studies comparing platform switching versus conventionally restored implants; *Journal of Clinical Periodontology*, 2012; 39: 1097-1113; DOI: 10.1111/j.1600-051X.2012.01930.x
- Csonka M.; Switching Platform chirurgico e protesico; *Italian Dental Journal*, 2012; 08: 24
- Lang N. P., Pun L., Lau K. Y., Li K. Y., Wong M. C.; A systematic review on survival and success rates of implants placed immediately into fresh extraction sockets after at least 1; *Clinical Oral Implants Research*, 2012; 23 (Suppl 5): 39-66; DOI: 10.1111/j.1600-0501.2011.02372.x
- Ortega Martinez J., Pérez Pascual T., Mereque Bueno S., Hernández Alfaro F., Ferrés Padró E.; Immediate Implants following tooth extraction
- A systematic review; *Medicina Oral Patología Oral y Cirugía Bucal*, 2012; 17: 251-261; DOI: 10.4317/medoral.17469
- Vignoletti F., Morante Mudarra S., Lorenzo Vignau R., Oteo Pérez A., Rodrigo Gómez D.; "Implantes inmediatos en alveolos postextracción. Factores críticos en la cicatrización de los tejidos duros y blandos"; *Maxilaris, Ciencia y Actualidad Profesional e Industrial del Sector Dental*, 2012, XV, 155: 110-126
- Bruschi G., Crespi R., Capparé P., Gherlone E.; Clinical study of flap design to increase the keratinized gingiva around implants. 4-year, follow-up; *Journal of Oral Implantology*, Early View, First published online in 2012, November; DOI: 10.1563/AAID-JOI-D-11-00236.1
- Canullo L., Gotz W.; Peri-implant hard tissue response to glow-discharged abutments: Prospective study, Preliminary radiological results; *Annals of Anatomy*, 2012; 194: 174-478; DOI: org/10.1016/j.aanat.2012.03.006
- Canullo L., Micarelli C., Clementini M.; Effect of titanium abutment plasma cleaning on peri-implant bone level changes: randomized controlled trial, preliminary results; Poster, Winner, Prize Martignoni, AIOF Congress Bologna, 22-24 Novembre 2012
- Bastieri A.; espansione ossea controllata con Drill Bone Expander (D.B.e.): variabili e polifunzionalità; *Numeri Uno* 15, 2013, 10-12
- Scavia S.; Studio prospettico sul mantenimento del volume osseo verticale in impianti inseriti con tecnica M.I.S.E.; *Numeri Uno* 14, 2012, 14-15
- Crespi R., Bruschi G. B.; Vantaggi chirurgici nell'uso del Magnetic Mallet; *Numeri Uno* 13, 2012, 16-18.
- Csonka M.; Postestrattivo a carico immediato con Tecnica Simple e Platform Switching; *Numeri Uno* 12, 2012, 8-9
- Minenna F., De Leo L.; Riabilitazione impianto protesica con tecnica One Stage e protesi avvitata in materiale composito; *Numeri Uno*, 12;2012, 12-13
- Micarelli C., Canullo L., Baldissara A., Clementini M.; Abutment screw removal torque values before and after plasma cleaning; *Clinical Oral Implant Research*, 2012; 23 Suppl 7: 72; DOI: 10.1111/clr.12019, 2012, 23(s7_162)
- Micarelli C., Canullo L., Baldissara P., Clementini M.; Abutment screw reverse torque values before and after plasma cleaning; *International Journal of Prosthodontics*, Accepted and Overview Published online, on 2012, September, 12th
- Peñarrocha Diago M., Pellicer Chover H., Peñarrocha Oltra D.; Rehabilitación con prótesis fija de arco completo maxilary mandibular sobre implantes postextracción. A propósito de un caso; *Numeri Uno* 11, 2012, 15-17
- Galli C., Piemontese M., Meikle S. T., Santin M., Macaluso G. M., Passeri G.; Biomimetic coating with phosphoserine-tethered poly(epsilon-lysine) dendrons on titanium surfaces enhances Wnt and osteoblastic differentiation; *Clinical Oral Implant Research*, Early View, First Published online on 2012, December 5th; DOI: 10.1111/j.1600-0501.2011.02227.x
- Bengazi F., Lang N. P., Canciani E., Viganò P., Urbizo Velez J., Botticelli D.; Osseointegration of implants with dendrimers surface characteristics installed conventionally or with Piezosurgery®. A comparative study in the dog; *Clinical Oral Implant Research*, Early View, First Published online on 2012, December 12th; DOI: 10.1111/clr.12082
- Schweikert M., Baffone G., Botticelli D., Favero G., Lavia P. P., Lang N. P.; Influence of buccal bony crest width on marginal dimensions of peri-implant tissues after implant installation in dogs; *Clinical Oral Implant Research*, 2012; 23 Suppl 7: 77-78; DOI: 10.1111/clr.12019, 2012, 23(s7_171)
- Baffone G. M., Botticelli D., Pereira F. P., Favero G., Schweikert M., Lang N. P.; Influence of buccal bony crest width on marginal dimensions of peri-implant hard and soft tissues after implant installation. An experimental study in dogs; *Clinical Oral Implants Research*, 2013; 24: 250-254; DOI: 10.1111/j.1600-0501.2012.02512.x
- Crespi R., Capparé P., Gherlone E.; A comparison of manual

- and electrical mallet in maxillary bone condensing for immediately loaded implants: a randomized study; *Clinical Implant Dentistry and Related Research*, Early View, First Published online on 2012, August, 15th, DOI: 10.1111/j.1708-8208.2012.00485.x
- Calvo-Guirado J. L., Boquete-Castro A., Negri B., Delgado Ruiz R., Gomez-Moreno G., Iezzi G.; Crestal bone reactions to immediate implants placed at different levels in relation to crestal bone. A pilot study in foxhound dogs; *Clinical Oral Implant Research*, Early View, First Published online on 2013, January 25th; DOI: 10.1111/clar.12110
 - Scala A., Lang N. P., Schweikert M. T., de Oliveira J. A., Rangel-Garcia I. Jr, Botticelli D.; Sequential healing of open extraction sockets. An experimental study in monkeys; *Clinical Oral Implant Research*, Early View, First Published online on 2013, April 1st; DOI: 10.1111/clar.12148
 - Rossi F., Lang N. P., Favero G., Pantani F., Tschon M., Botticelli D.; Bone healing pattern at the surface of titanium implants: an experimental study in the dog; *Clinical Oral Implant Research*, 2012; 23 Suppl 7: 76-77; DOI: 10.1111/clar.12019, 2012, 23(s7_171)
 - Sivolella S., Bressan E., Salata L. A., Urrutia Z. A., Lang N. P., Botticelli D.; Osteogenesis at implants without primary bone contact - An experimental study in dogs; *Clinical Oral Implant Research*, 2012; 23: 542-549, DOI: 10.1111/j.1600-0501.2012.02423.x
 - Sivolella S., Bressan E., Salata L. A., Quiñones M. E., Urrutia Z. A., Lang N. P., Botticelli D.; Deproteinized bovine bone mineral particles and osseointegration of implants without primary bone contact: an experimental study in dogs; *Clinical Oral Implant Research*, Early View, First Published online on 2013, April 8th; DOI: 10.1111/clar.12154
 - Caneva M., Botticelli D., Viganò P., Morelli F., Rea M., Lang N. P.; Connective tissue grafts in conjunction with implants installed immediately into extraction sockets. An experimental study in dogs; *Clinical Oral Implant Research*, 2013; 24: 50-56; DOI: 10.1111/j.1600-0501.2012.02450.x
 - De Santis E., Lang N. P., Cesaretti G., Mainetti T., Beolchini M., Botticelli D.; Healing outcomes at implants installed in sites augmented with particulate autologous bone and xenografts. An experimental study in dogs; *Clinical Oral Implants Research*, 2013; 24: 77-86; DOI: 10.1111/j.1600-0501.2012.02456.x
 - Negri M., Lumetti S., Manfredi E., Galli C., Chiacci G., Macaluso G. M.; Marginal bone remodelling of Sweden&Martina Premium implants: 2-years clinical results; *Clinical Oral Implant Research*, 2012; 23 Suppl 7: 98; DOI: 10.1111/clar.12019, 2012, 23(s7_218)
 - Cosyn J., Hooghe N., De Bruyn H.; A systematic review on the frequency of advanced recession following single Immediate Implant treatment; *Journal of Clinical Periodontology*, 2012 Jun; 39: 582-589; DOI: 10.1111/j.1600-051X.2012.01888.x
 - Covani U., Chiappe G., Bosco M., Orlando B., Quaranta A., Barone A.; A 10-year evaluation of implants placed in fresh extraction sockets: a prospective cohort study; *Journal of Periodontology*, 2012; 83: 1226-1234; DOI: 10.1902/jop.2012.110583
 - Covani U., Ricci M., D'Ambrosio N., Quaranta A., Barone A.; Changes in soft tissues around immediate full-arch rehabilitations: a prospective study; *Clinical Oral Implant Research*, Early View, First Published online on 2012, January, 6th; DOI: 10.1111/j.1600-0501.2011.02394.x
 - Crespi R., Capparè P., Gherlone E., Romanos G.; Immediate provisionalization of dental implants placed in fresh extraction sockets using a flapless technique; *The International Journal of Periodontics & Restorative Dentistry*, 2012; 32: 29-37
 - Morelli F.; Rigenerazione ossea orizzontale e verticale peri-implantare con mesh in titanio ed osso autologo; *Numeri Uno* 11; 2011, 7-9
 - Crespi R., Capparè P., Gherlone E.; Electrical mallet provides essential advantages in maxillary bone condensing. A prospective clinical study; *Clinical Implant Dentistry and Related Research*, Early View, First Published online on 2012, January, 11th, DOI: 10.1111/j.1708-8208.2011.00432.x
 - Galli C., Macaluso G.M., Elezi E., Ravanetti F., Cacchioli A., Gualini G., Passeri G.; The Effects of Er:YAG Laser Treatment on Titanium Surface Profile and Osteoblastic Cell Activity: An In Vitro Study; *Journal of Periodontology*, 82 (8): 1169-1177, 2011; DOI: 10.1902/jop.2010.100428
 - Ramaglia L., Postiglione L., Di Spigna G., Capece G., Salzano S., Rossi G.; Sandblasted-acid-etched titanium surface influences in vitro the biological behavior of SaOS-2 human osteoblast-like cells; *Dental Material Journal*, 30: 183-192, 2011; DOI:10.4012/dmj.2010-107
 - Scala A., Botticelli D., Faeda R.S., Rangel I.G. Jr., de Oliveira J.A., Lang N.P.; Lack of influence of the Schneiderian membrane in forming new bone apical to implants simultaneously installed with sinus floor elevation: an experimental study in monkeys; *Clinical Oral Implant Research*, Early View, First Published online on 2011, June 13th; DOI: 10.1111/j.1600-0501.2011.02227.x
 - Rossi F., Botticelli D., Pantani F., Pereira F.P., Salata L.A., Lang N.P.; Bone healing pattern in surgically created circumferential defects around submerged implants: an experimental study in dog; *Clinical Oral Implant Research*, Early View, First Published online on 2011, March 28th; DOI: 10.1111/j.1600-0501.2011.02170.x
 - Caneva M., Botticelli D., Pantani F., Baffone G.M., Rangel I.G. Jr., Lang N.P.; Deproteinized bovine bone mineral in marginal defects at implants installed immediately into extraction sockets: an experimental study in dogs; *Clinical Oral Implant Research*, Early View, First Published online on 2011, May 5th; DOI: 10.1111/j.1600-0501.2011.02202.x
 - De Santis E., Botticelli D., Pantani F., Pereira F.P., Beolchini M., Lang N.P.; Bone regeneration at implants placed into extraction sockets of maxillary incisors in dogs; *Clinical Oral Implant Research* 22, 2011; 430-437; DOI: 10.1111/j.1600-0501.2010.02122.x
 - De Santis E., Lang N.P., Scala A., Viganò P., Salata L.A., Botticelli D.; Healing outcomes at implants installed in grafted sites: an experimental study in dogs; *Clinical Oral Implant Research*, Early View, First Published online on 2011, October 3rd; DOI: 10.1111/j.1600-0501.2011.02326.x
 - Caneva M., Botticelli D., Morelli F., Cesaretti G., Beolchini M., Lang N.P.; Alveolar process preservation at implants installed immediately into extraction sockets using deproteinized bovine bone mineral - an experimental study in dogs; *Clinical Oral Implant Research*, Early View, First Published online on 2011, October 21st; DOI: 10.1111/j.1600-0501.2011.02332.x
 - Caneva M., Botticelli D., Rossi F., Carvalho Cardoso L., Pantani F., Lang N.P.; Influence of implants with different sizes and configurations installed immediately into extraction sockets on peri-implant hard and soft tissues: an experimental study in dogs; *Clinical Oral Implant Research*, Early View, First Published online on 2011, September 29th; DOI: 10.1111/j.1600-0501.2011.02310.x
 - Vignoletti F., De Sanctis M., Sanz M.; Impianti immediati post-estrattivi: fattori critici per la guarigione dei tessuti; *Il Dentista Moderno*, 9:94-114, 2011
 - Farronato D., Santoro G., Canullo L., Botticelli D., Maiorana C., Lang N.P.; Establishment of the epithelial attachment and connective tissue adaptation to implants installed under the concept of "platform switching": a histologic study in minipigs; *Clinical Oral Implant Research*, Early View, First Published online on 2011, April 15th; DOI: 10.1111/j.1600-0501.2011.02196.x
 - Baffone G.M., Botticelli D., Pantani F., Cardoso L.C., Schweikert M.T., Lang N.P.; Influence of various 165 implant platform configurations on peri-implant tissue dimensions: an experimental study in dog; *Clinical Oral Implant Research* 22, 2011; 438-444; DOI: 10.1111/j.1600-0501.2010.02146.x
 - Canullo L., Pellegrini G., Allievi C., Trombelli L., Annibaldi S., Della Via C.; Soft tissues around long-term platform switching implant restorations: a histological human evaluation. Preliminary results; *Journal of Clinical Periodontology*, 2011; 38: 86-94; DOI: 10.1111/j.1600-051X.2010.01641.x
 - Canullo L., Iannello G., Netuschil L., Jepsen S.; Platform switching and matrix metalloproteinase-8 levels in peri-implant sulcular fluid; *Clinical Oral Implant Research*, Early View, First Published online on 2011, March 28th; DOI: 10.1111/j.1600-0501.2011.02175.x
 - Della Via C., Canullo L., Allievi C., Lang N.P., Pellegrini C.; Soft tissue surrounding switched platform implants: an immunohistochemical evaluation; *Clinical Oral Implant Research*, Early View, First Published online on 2011, September 29th; DOI: 10.1111/j.1600-0501.2011.02301.x
 - Baffone G.M., Botticelli D., Canullo L., Scala A., Beolchini M., Lang N.P.; Effect of mismatching abutments on implants with wider platforms - an experimental study in dogs; *Clinical Oral Implant Research*, Early View First Published online on 2011, November 2nd; DOI: 10.1111/j.1600-0501.2011.02320.x
 - Canullo L., Pace F., Coelho P., Sciubba E., Vozza I.; The Influence

- of Platform Switching on the Biomechanical Aspects of the Implant-Abutment System. A Three Dimensional Finite Element Study; *Med Oral Patol Oral Cir Bucal*. 2011 Sep 1;16 (6):e852-6; DOI:10.4317/medoral.17243
- Canullo L., Iannello G., Götz W.; The influence of individual bone patterns on peri-implant bone loss: preliminary report from a 3-year randomized clinical and histologic trial in patients treated with implants restored with matching-diameter abutments or the platform-switching concept; *International Journal of Oral and Maxillofacial Implants*, 2011 May-Jun;26(3):618-30
 - Serrano-Sánchez P., Calvo-Guirado J.L., Manzanera-Pastor E., Lorrio-Castro C., Bretones-López P., Pérez-Llanes J.A.; The influence of platform switching in dental implants. A literature review; *Medicina Oral Patología Oral Cirugía Bucal*. 2011 May 1;16 (3):e400-5; DOI: 10.4317/medoral.16.e400
 - Bruschi G.B., Crespi R., Cappare P., Bravi F., Bruschi E., Gherlone E.; Localized Management of Sinus Floor Technique for Implant Placement in Fresh Molar Sockets; *Clinical Implant Dentistry and Related Research*, 2011 May 20. [Epub ahead of print]; DOI: 10.1111/j.1708-8208.2011.00348.x
 - Sisti A., Canullo L., Mottola M.P., Iannello G.; A case series on crestal sinus elevation with rotary instruments; *European Journal of Oral Implantology*. 2011 Summer;4(2):145-52
 - Garcia-Fajardo Palacios C.; Sinus Lift. Ottimizzazione dei risultati; *NumeriUno* 10(06), 2011, 04-07
 - Canullo L.; RIGENERAZIONE DI UN SITO POST-ESTRATTIVO con grave deficit osseo vestibolare con idrossiapatite arricchita di magnesio. CASE REPORT CON FOLLOW UP DEL RESTAURO IMPLANTOPROTESICO A 2 ANNI; *Odontoiatria Rivista degli Amici di Brugg*, 2: 166-167, 2011
 - Becattelli A., Biscaro L., Ferlin P., Soattin M.; Riabilitazione implanto-protetica di entrambe le arcate mediante Toronto Bridge su impianti tiltati a carico immediato; *NumeriUno* 10(06) 2011, 10-12
 - Marano G., Tomarelli F.; Carico implantare immediato e condizionamento dei tessuti molli con provvisorio in ceramica; *NumeriUno* 10 (06) 2011, 18-21
 - Avanzo P., Fabrocini L., Avanzo A., Ciavarella D., Lo Muzio L., De Maio R.; Use of intra-oral welding to stabilize dental implants in augmented sites for immediate provisionalization: a case report; *Journal of Oral Implantology*, 2010 Oct 8. [Epub ahead of print]; DOI: 10.1563/AAID-JOID-10-00047
 - Dominci A.D.; Solidarizzazione elettronica su impianti a carico immediato: un caso clinico in chirurgia flapless; *Dental Cadmos*, 79(8):545-550, 2011; DOI: 10.1016/j.cadmos.2011.03.002
 - De Paolis G., Quaranta A., Zappia S., Voza I., Quaranta M.; Valutazione clinica e microbiologica di impianti a connessione conometrica rispetto a impianti a connessione esagonale: caso clinico; *Dental Cadmos*, 79(7):443-454, 2011; DOI: 10.1016/j.cadmos.2010.12.010
 - Canullo L., Bignozzi I., Cocchetto R., Cristalli M.P., Iannello G.; Immediate positioning of a definitive abutment versus repeated abutment replacements in post-extractive implants: 3-year follow-up of a randomised multicentre clinical trial; *European Journal of Oral Implantology*, 2010 Winter;3(4):285-96
 - Csonka M.; Carico Immediato di una Cresta Mandibolare Edentula con Tecnica SIMPLE; *Italian Dental Journal*, 2011
 - Canullo L., Baffone G.M., Botticelli D., Pantani F., Beolchini M., Lang N.P.; Effect of wider implant/ abutment mismatching: an histological study in dogs; *Clinical Oral Implant Research*, 22(9), 2011:910; DOI: 10.1111/j.1600-0501.2011.02271.x
 - Rossi F., Botticelli D., Salata L.; Bone healing in animal surgically created circumferential defects around submerged implants; *Clinical Oral Implant Research*, 22(9), 2011: 937; DOI: 10.1111/j.1600-0501.2011.02271.x
 - Ricci M., Funel N., Orazio V., Bobbio A., Barone A., Covani U.; Analysis of osteoblastic gene dynamics in the early human mesenchymal cell response to an implant support: an in vitro study; *Clinical Oral Implant Research*, 22(9), 2011: 1071; DOI: 10.1111/j.1600-0501.2011.02271.x
 - Canullo L., Gotz W.; Cell growth on titanium disks treated by plasma of Argon: experimental study; *Clinical Oral Implant Research*, 22(9), 2011: 1082-3; DOI: 10.1111/j.1600-0501.2011.02271.x
 - Bruschi G. B., Crespi R.; TECNICHE DI ESPANSIONE OSSEA IN CHIRURGIA IMPLANTARE; *Quintessenza Edizioni S.r.l.*, 2011, Milano (Anteprima)
 - Avellino W., Milan U., Delle Rose D.; SOLUZIONI CLINICHE E TECNICHE PER LA REALIZZAZIONE DI UN PROVVISORIO FULL-ARCH SU IMPIANTI CON FUNZIONE IMMEDIATA; *NumeriUno*, 7: 11-13, 2010
 - Branchi R., Vangi D., Virga A., Guertin G., Fazi G.; RESISTANCE TO WEAR OF FOUR MATRICES WITH BALL ATTACHMENTS FOR IMPLANT OVERDENTURES: A FATIGUE STUDY; *Journal of Prosthodontics*, 19(8):614-619, 2010
 - Bruschi G.B., Crespi R., Cappare P., Gherlone E.; TRANSCRESTAL SINUS FLOOR ELEVATION: A RETROSPECTIVE STUDY OF 46 PATIENTS UP TO 16 YEARS; *Clinical Implant Dentistry and Related Research*, 2010 Oct 26
 - Caneva M., Salata L.A., Scombatti de Souza S., Baffone G., Lang N.P., Botticelli D.; INFLUENCE OF IMPLANT POSITIONING IN EXTRACTION SOCKETS ON OSSEOINTEGRATION: HISTOMORPHOMETRIC ANALYSES IN DOGS; *Clinical Oral Implant Research* 21; 43-49, 2010
 - Caneva M., Salata L.A., Scombatti de Souza S., Bressan E., Botticelli D., Lang N.P.; HARD TISSUE FORMATION ADJACENT TO IMPLANTS OF VARIOUS SIZE AND CONFIGURATION IMMEDIATELY PLACED INTO EXTRACTION SOCKETS: AN EXPERIMENTAL STUDY IN DOGS; *Clinical Oral Implant Research*, 21(9):885-90, 2010
 - Caneva M., Botticelli D., Stellini E., Souza S.L., Salata L.A., Lang N.P.; MAGNESIUM-ENRICHED HYDROXYAPATITE AT IMMEDIATE IMPLANTS: A HISTOMORPHOMETRIC STUDY IN DOGS; *Clinical Oral Implant Research*, Early View, first published online 2010 Dec 9
 - Caneva M., Botticelli D., Salata L.A., Scombatti de Souza S., Carvalho Cardoso L., Lang N.P.; COLLAGEN MEMBRANES AT IMMEDIATE IMPLANTS: A HISTOMORPHOMETRIC STUDY IN DOGS; *Clinical Oral Implant Research*, 21(9):891-7, 2010
 - Caneva M., Botticelli D., Salata L.A., Scombatti de Souza S.L., Bressan E., Lang N.P.; FLAP VS. "FLAPLESS" SURGICAL APPROACH AT IMMEDIATE IMPLANTS: A HISTOMORPHOMETRIC STUDY IN DOGS; *Clinical Oral Implant Research*, 21 (12):1314-1319, 2010
 - Canullo L., Quaranta A., Teles R.P.; THE MICROBIOTA ASSOCIATED WITH IMPLANTS RESTORED WITH PLATFORM SWITCHING: A PRELIMINARY REPORT; *Journal of Periodontology*, 81:403-411, 2010
 - Canullo L., Rossi Fedele G., Iannello G., Jepsen S.; PLATFORM SWITCHING AND MARGINAL BONELEVEL ALTERATIONS: THE RESULTS OF A RANDOMIZEDCONTROLLED TRIAL; *Clinical Oral Implant Research*, 21:115-121, 2010
 - Canullo L., Bignozzi I., Cocchetto R.; "ONE ABUTMENT-ONE TIME": OPTIMIZING PLATFORMSWITCHING CONCEPT. THREE-YEAR CONTROLLED PROSPECTIVE STUDY; *Clinical Oral Implant Research*, 21 (10): 1085, 2010
 - Canullo L.; CASO CLINICO: AGENESIA DELL'INCISIVO LATERALE SUPERIORE DESTRO; *Italian Dental Journal*, 4: 16, 2010
 - Canullo L., Cocchetto R., Loi I.; PERI-IMPLANT TISSUES REMODELING: SCIENTIFIC BACKGROUND & CLINICAL IMPLICATIONS; *Quintessenza Edizioni S.r.l.*, 2010, Milano (Anteprima)
 - Canullo L., Sisti A.; EARLY IMPLANT LOADING AFTER VERTICAL RIDGE AUGMENTATION (VRA) USING E-PTFE TITANIUMREINFORCED MEMBRANE AND NANOSTRUCTURED HYDROXYAPATITE: 2-YEAR PROSPECTIVE STUDY; *European Journal Oral Implantology*, 3(1):59-69, 2010
 - Canullo L., Patacchia O., Sisti A., Heinemann F.; IMPLANT RESTORATION 3 MONTHS AFTER ONE STAGE SINUS LIFT SURGERY IN SEVERELY RESORBED MAXILLAE: 2-YEAR RESULTS ON A MULTICENTER PROSPECTIVE CLINICAL STUDY; *Clinical Implant Dentistry and Related Research*, Early view - Published online in ahead of printing, 21-10-2010
 - Ciccù M., Risitano G., Maiorana C., Herford A., Oteri G., Ciccù D.; "TORONTO" SCREWED MANDIBULAR OVERDENTURE ON DENTAL IMPLANTS: FEM AND VON MISES ANALYSIS OF STRESS DISTRIBUTION; *The Journal of Implants and Advanced Dentistry*, 2(9): 41-58, 2010
 - Covani U., Marconcini S., Santini S., Cornelini R., Barone A.; IMMEDIATE RESTORATION OF SINGLE IMPLANTS PLACED IMMEDIATELY AFTER IMPLANT REMOVAL. A CASE REPORT; *International Journal of Periodontics & Restorative Dentistry*, 30:639-645, 2010
 - Crespi R., Cappare P., Gherlone E.; OSTEOHOME SINUS FLOOR ELEVATION AND SIMULTANEOUS IMPLANT PLACEMENT IN GRAFTED BIOMATERIAL SOCKETS: 3 YEARS OF FOLLOW-UP; *Journal of Periodontology*, 81:344-349, 2010
 - Crespi R., Cappare P., Gherlone E.; A 4-YEAR EVALUATION OF THE PERI-IMPLANT PARAMETERS OF IMMEDIATE LOADED

- IMPLANTS PLACED IN FRESH EXTRACTION SOCKETS; *Journal of Periodontology*, 81 (11):1629-1634, 2010
- Crespi R., Capparè P., Gherlone E.; IMMEDIATE LOADING OF DENTAL IMPLANTS PLACED IN PERIODONTALLY INFECTED AND NON INFECTED SITES IN HUMANS: A FOUR YEARS FOLLOW-UP CLINICAL STUDY; *Journal of Periodontology*, 81 (8):1140-1146, 2010
 - Crespi R., Capparè P. and Gherlone E.; FRESH-SOCKET IMPLANTS IN PERIAPICAL INFECTED SITES IN HUMANS; *Journal of Periodontology*, 81:378-383, 2010
 - Galli C., Passeri G., Piemontese M., Lumetti S., Manfredi E., Carra M.C., Macaluso G.M.; PHOSPHOSERINE-POLY (LYSINE) COATINGS PROMOTE OSTEOBLASTIC DIFFERENTIATION AND WNT SIGNALING ON TITANIUM SUBSTRATES; *Clinical Oral Implant Research*, 21(10): 1172, 2010
 - Mantoan G.; LE CORONE PROVVISORIE IMMEDIATE SU IMPIANTI GLOBAL (METODICA CLINICA); *NumeriUno*, 7: 17-18, 2010
 - Momen A. A., Hadeel M. I., Ahmad H. A.; PLATFORM SWITCHING FOR MARGINAL BONE PRESERVATION AROUND DENTAL IMPLANTS: A SYSTEMATIC REVIEW AND META-ANALYSIS; *Journal of Periodontology*, 81 (10):1350-1366, 2010
 - Pantani F., Botticelli D., Rangel Garcia I. Jr., Salata L.A., Jayme Borges G., Lang N. P.; INFLUENCE OF LATERAL PRESSURE TO THE IMPLANT BED ON OSSEointegration: AN EXPERIMENTAL STUDY IN DOGS; *Clinical Oral Implant Research*, 21(11): 1264-70, 2010
 - Passeri G., Cacchioli A., Ravanetti F., Galli C., Elezi E., Macaluso G.M.; ADHESION PATTERN AND GROWTH OF PRIMARY HUMAN OSTEOBLASTIC CELLS ON FIVE COMMERCIALY AVAILABLE TITANIUM SURFACES; *Clinical Oral Implant Research* 21: 756-765, 2010
 - Raddi F.; ANALISI COMPARATIVA TEST DI RESISTENZA A FATICA SPERIMENTALI E VIRTUALI; Relazione interna, Sweden & Martina, 2010
 - Scala A., Botticelli D., Oliveira J.A., Okamoto R., Garcia Rangel I. Jr., Lang N.P.; EARLY HEALING AFTER ELEVATION OF THE MAXILLARY SINUS FLOOR APPLYING A LATERAL ACCESS - A HISTOLOGICAL STUDY IN MONKEYS; *Clinical Oral Implant Research*, 21 (12): 1320-6, 2010
 - Silvasan M.H.; TIMING OF DENTAL IMPLANT LOADING - A LITERATURE REVIEW; *Implants - Oemus*, 11 (3): 06-16, 2010
 - Sbordone L, Levin L, Guidetti F, Sbordone C, Glikman A, Schwartz-Arad D.; APICAL AND MARGINAL BONE ALTERATIONS AROUND IMPLANTS IN MAXILLARY SINUS AUGMENTATION GRAFTED WITH AUTOGENOUS BONE OR BOVINE BONE MATERIAL AND SIMULTANEOUS OR DELAYED DENTAL IMPLANT POSITIONING; *Clinical Oral Implants Research*. , 2010 Nov 19. [Epub ahead of print]
 - Ballini D., Attini M., Giunta S., Mezzanotte E.; MINI IMPIANTI: UN CASE REPORT; *NumeriUno*, 5: 18-20, 2009
 - Biscaro L., Becattelli A., Soattin M.; RIABILITAZIONE IMPLANTO-PROTESICA DELLE DUE ARCADE CON CARICO IMMEDIATO: PROTOCOLLO DI LAVORO CON L'UTILIZZO DELLA TECNICA DEL MODELLO UNICO E DELLA SISTEMATICA PAD; *NumeriUno*, 8, 04-05, 2009
 - Briguglio F., Briguglio E., Sidoti Pinto G.A., Lapi M., Zappia D., Briguglio R.; VALUTAZIONE CLINICA COMPARATIVA SULL'UTILIZZO DI UN COPOLIMERO DELL'ACIDO POLIGLICOLICO E POLILATTICO NEL SINUS LIFT; *Implantologia*.1:9-14, 2009
 - Bruschi G. B., Bravi F., Di Felice A.; RIABILITAZIONE PROTESICA SU DENTI E IMPIANTI MEDIANTE TECNICHE CHIRURGICHE DI ESPANSIONE CRESTALE E SOLLEVAMENTO DEL SENO E CHIRURGIA PROTESICAMENTE GUIDATA; *NumeriUno*, 5: 8-14, 2009
 - Calesini G., Micarelli C., Coppe S., Scipioni A.; EDENTULOUS SITE ENHANCEMENT: A REGENERATIVE APPROACH TO THE MANAGEMENT OF EDENTULOUS AREAS. PART 2- PERI-IMPLANT TISSUES; *International Journal of Periodontics & Restorative Dentistry*, 29(1):49-57, 2009
 - Canullo L., Iurlaro G., Iannello G.; DOUBLE-BLIND RANDOMIZED CONTROLLED TRIAL STUDY ON POSTEXTRACTION IMMEDIATELY RESTORED IMPLANTS USING THE SWITCHING PLATFORM CONCEPT: SOFT TISSUE RESPONSE. PRELIMINARY REPORT; *Clinical Oral Implant Research*, 20 (4):414-420, 2009
 - Canullo L., Goglia G., Iurlaro G., and Iannello G.; SHORT-TERM BONE LEVEL OBSERVATIONS ASSOCIATED WITH PLATFORM SWITCHING IN IMMEDIATELY PLACED AND RESTORED SINGLE MAXILLARY IMPLANTS: A PRELIMINARY REPORT; *International Journal of Prosthodontics*, 22 (3):277-282, 2009
 - Canullo L., Iannello G., Jepsen S.; MATRIX-METALLOPROTEINASES AND BONE LOSS AT IMPLANTS RESTORED ACCORDING TO THE PLATFORM SWITCHING CONCEPT: A RANDOMIZED CONTROLLED TRIAL ON THE INFLUENCE OF DIFFERENT MISMATCHING; *Clinical Oral Implant Research*, 20(9):873-874, 2009
 - Canullo L., Vozza I., Caricato F., Dellavia C.; MAXILLARY SINUS FLOOR AUGMENTATION USING A NANO-CRYSTALLINE HYDROXYAPATITE SILICA GEL. A PROSPECTIVE STUDY - HISTOLOGICAL RESULTS AFTER 3 MONTHS OF HEALING; *Implants* 2, 24-27, 2009
 - Cardelli P., Montani M., Gallio M., Biancolini M., Brutti C., Barlattani A.; ABUTMENTS ANGOLATI E TENSIONI PERIMPLANTARI: ANALISI F.E.M.; *Oral Implantology*, 1:7-14, 2009
 - Carinci F., Guidi R., Franco M., Viscioni A., Rigo L., De Santis B., Tropina E.; IMPLANTS INSERTED IN FRESH-FROZEN BONE: A RETROSPECTIVE ANALYSIS OF 88 IMPLANTS LOADED 4 MONTHS AFTER INSERTION; *Quintessence International*, 40(5): 413-419, 2009
 - Carusi G., Sisti A., Mottola M.P., Matera G., Veruggio P., Gelmi L., Bailo A.; TECNICA DI RIALZO DI SENO MINIMAMENTE INVASIVA NEL TRATTAMENTO IMPLANTARE DEL MASCELLARE EDENTULO; *Dental Cadmos*, 77(10): 31-40, 2009
 - Ceccherini A., De Angelis L., Silvestrelli S.; CHIRURGIA SOFTWARE ASSISTITA CON LA TECNICA MODEL GUIDE: PROGETTO 3D - POSA DELL'IMPIANTO GUIDATA; *TeamWork*, 11(6), 63:75, 2009



rev. 03-15



Sweden & Martina S.p.A.

Via Veneto, 10
35020 Due Carrare (PD), Italy
Tel. +39.049.9124300
Fax +39.049.9124290
info@sweden-martina.com
www.sweden-martina.com

Sweden & Martina Mediterranea S.L.

Sorolla Center, Oficina 801
Avda Cortes Valencianas 58, 8pl
46015-Valencia, España
Tel. +34.96.3525895
Tel. 900993963
info.es@sweden-martina.com

Sweden & Martina Inc.

One Embarcadero Center
Suite#504
San Francisco, CA94111
USA
Toll free (844)8MARTINA/844.862.7846
info.us@sweden-martina.com



The implants, standard prosthetic components and surgical instruments contained in this catalogue are Medical Devices and are manufactured by Sweden & Martina S.p.A. They are conform to the UNI EN ISO 9001:2008 / UNI EN 13485:2012 standards and are certified with the CE Mark (Class I) and CE 0476 mark (Class IIA and class IIB) in compliance with European Medical Device Directive No. 93/42 and European Directive No. 2007/47/CE.

We have met the good manufacturing standards (GMP) set forth by many countries worldwide, including the United States FDA.

The contents are updated at the time of publication. Check with the company for any subsequent updates.

All trademarks herein are the property of Sweden & Martina S.p.A. unless otherwise indicated.
This material is intended for laboratories and clinicians and is not intended for patient distribution.
This material is not to be redistributed, duplicated, or disclosed without the express written consent of Sweden & Martina S.p.A.
For additional product information, including indications, contraindications, warnings, precautions, and potential adverse effects, see Sweden & Martina S.p.A. website.